

# Cabina multifunzioni Multifunction cabin



**K500**

**K750**

## Corner

Modelli - Versions

80x80

90x90



Ed 03/22

Istruzioni di montaggio  
Assembly instructions

IT

EN



## Prima dell'installazione - *Before installation*

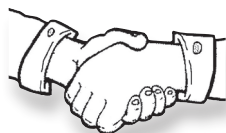

**Vi ringraziamo per aver scelto  
un nostro prodotto**

***We thank You for choosing  
one of our products***



## **Indice - *Index***

- Ingombri .....	Pag. 5
- <i>Overall dimensions</i>	
- Componenti fornitura .....	Pag. 6
- <i>Supplied components</i>	
- Attrezzatura necessaria .....	Pag. 14
- <i>Necessary equipment</i>	
- Sequenza di montaggio .....	Pag. 15
- <i>Assembly sequence</i>	
- Informazioni sull'utilizzo .....	Pag. 74
- <i>Information on use</i>	

## Prima dell'installazione - Before installation

### **IMPORTANTE**

**Prima di iniziare l'installazione leggere il presente libretto istruzioni.**



### **IMPORTANT**

**Read the following instruction manual before starting installation.**

- Dopo aver rimosso i componenti dagli imballi, verificare visivamente che gli stessi non presentino difetti.
- Qualsiasi difetto deve essere segnalato al fornitore prima dell'assemblaggio delle varie parti e dell'installazione.
- Qualsiasi reclamo relativo a imperfezioni del prodotto sarà accettato **SOLO** se segnalato prima dell'assemblaggio delle varie parti e dell'installazione.

**Verificare la presenza di tutti i componenti prima di iniziare il montaggio.**

- *After removing the components from packaging, visually check they do not show any defect.*
- *Any defect must be reported to the supplier before assembling the various parts and before installation.*
- *Any complaint related to imperfections of the product will be accepted **ONLY** if reported before assembling the various parts and before installation.*

**Check for the presence of all components before assembly.**



**Eeguire l'installazione e l'assemblaggio della cabina rispettando la sequenza illustrata.**

**Carry out the cabin installation and assembly observing the shown sequence.**

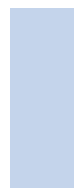

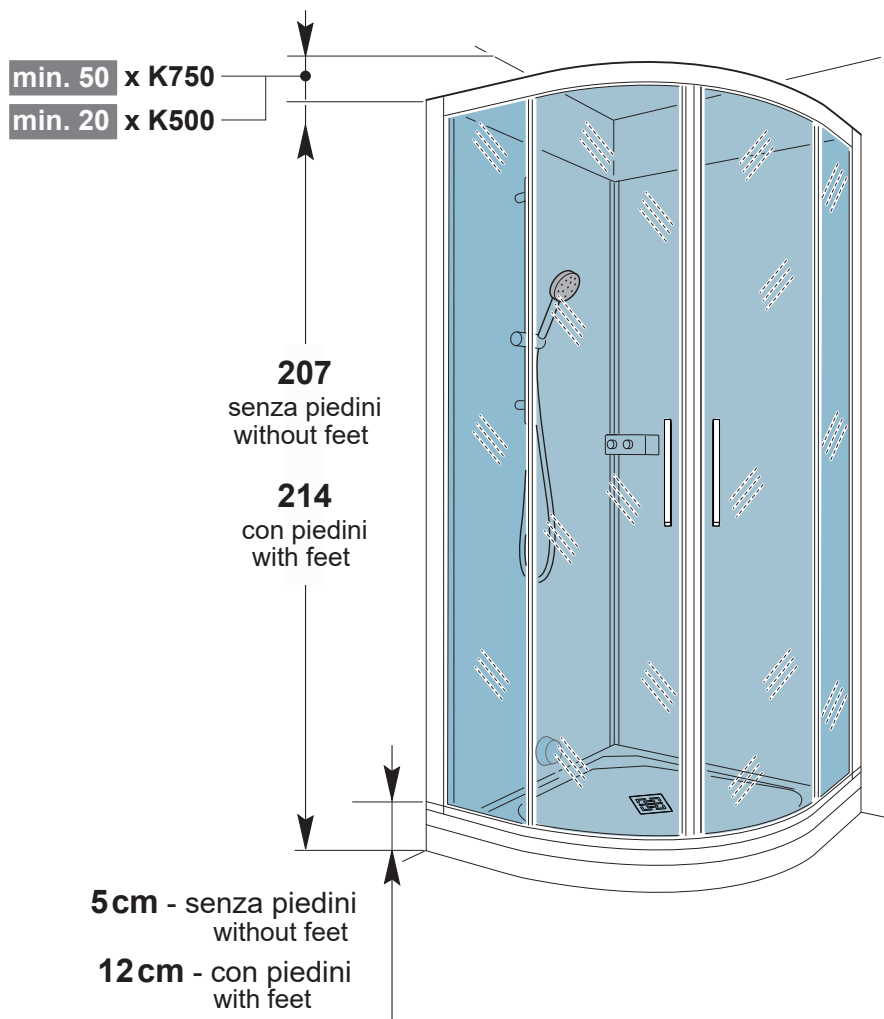

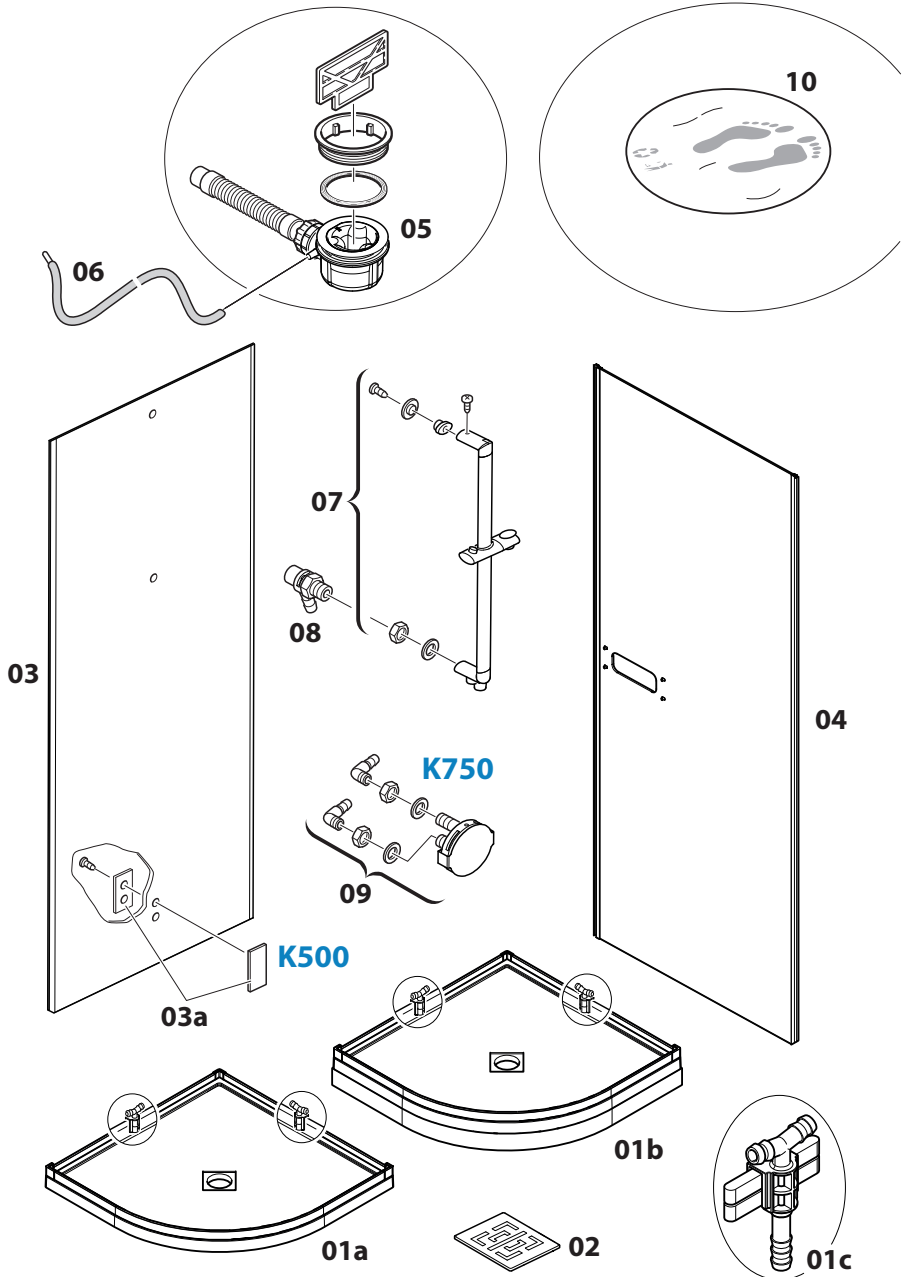

Rif.	Cod.	K500	K750
01a		●	●
01b		●	●
01c		●	●
02		●	●
03		●	●
03a		●	
04		●	●
05		●	●
06a			●
06b			●
06c			●
07		●	●
08		●	●
09			●
10		●	●

**6a**

corto  
short



1x

**6b**

lungo  
long

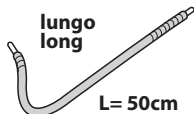

1x

**6c**

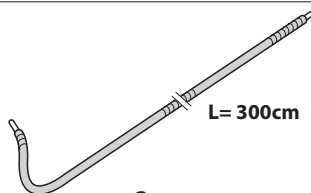

2x

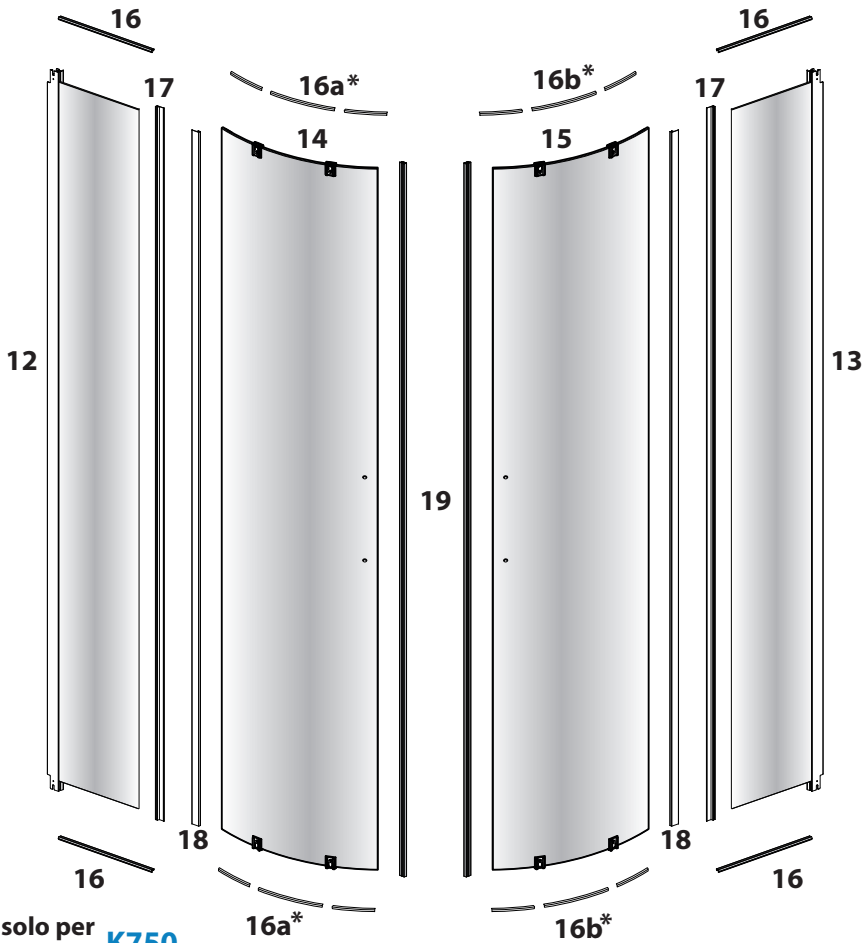
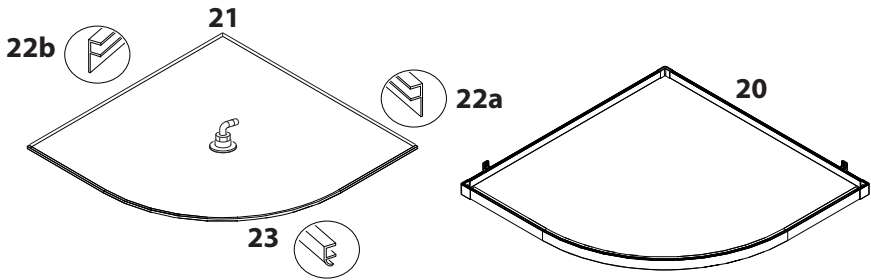

\* solo per  
only for **K750**

**COMPONENTI FORNITURA  
SUPPLIED COMPONENTS****4/08**

<b>Rif.</b>	<b>Cod.</b>	<b>K500</b>	<b>K750</b>
11		●	●
12		●	●
13		●	●
14		●	●
15		●	●
16		●	●
16a			●
16b			●
17		●	●
18		●	●
19		●	●
20		●	●
21		●	●
22a		●	●
22b			
23		●	●

S01

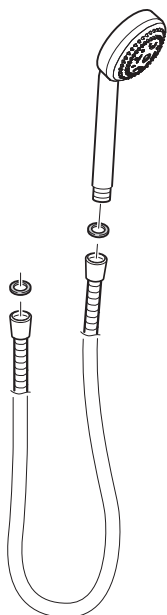

S02

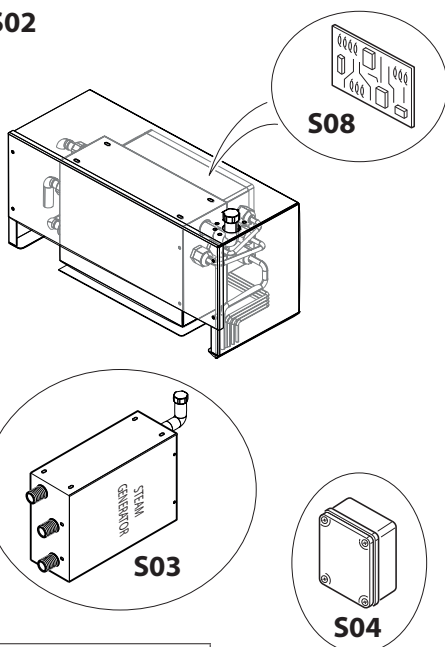

S05

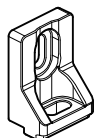

2x

S06



4x

S07



4x

S09

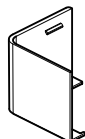

2x

S10

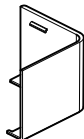

2x

S11

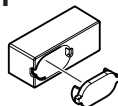

2x

S12

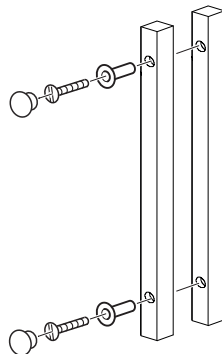

2x

S13

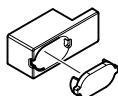

2x

S14

S15

Rif.	Cod.	K500	K750
S01		●	●
S02			●
S03			●
S04			●
S05			●
S06		●	●
S07		●	●
S08			●
S09		●	●
S10		●	●
S11		●	●
S12		●	●
S13		●	●
S14			
S15			
S16		●	●
S17		●	●
S18		●	●
S19		●	●

**S16**

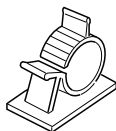

**10x**

**S17**



**5x**

**S18**

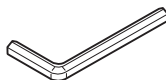





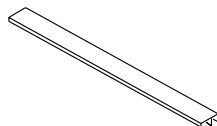







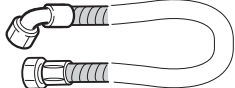

**1x**

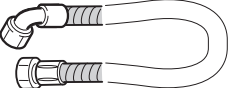
**S19**

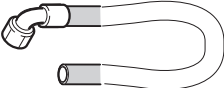

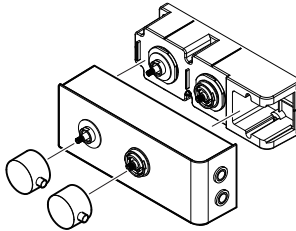
**4x**

<p><b>S20</b></p>  <p>3x</p>	<p><b>S21</b></p>  <p>2x + 2x (K750)</p>	<p><b>S22</b></p>  <p>ST3.5x25</p> <p>2x + 2x (K750)</p>
<p><b>S23</b></p>  <p>ST3.9x7.5</p> <p>4x</p>	<p><b>S24</b></p>  <p><b>S24a</b></p>  <p>1x</p>	<p><b>S25</b></p>  <p>1x</p>
<p><b>S26</b> 800mm</p>   <p>1x</p>	<p><b>S27</b> 1600mm</p>   <p>1x</p>	<p><b>S28</b> 2500mm</p>  <p>1x</p>
<p><b>S29</b> 1200mm</p>  <p>3x</p>	<p><b>S30</b></p>  <p>M4x25</p> <p>4x</p>	<p><b>S31</b></p> 
<p><b>S32</b></p>  <p>ST3.9x12</p> <p>4x</p>		



**Verificare la presenza di tutti i componenti prima di iniziare il montaggio.**



***Check for the presence of all the components before assembly.***

<b>Rif.</b>	<b>Cod.</b>	<b>K500</b>	<b>K750</b>
S20		●	●
S21		●	●
S22		●	●
S23		●	●
S24		●	●
S24a		●	
S25		●	●
S26		●	●
S27		●	●
S28		●	●
S29		●	●
S30		●	●
S31		●	●
S32		●	●

**Attrezzatura necessaria per l'installazione - NON FORNITI**  
**Equipment necessary for installation - NOT SUPPLIED**

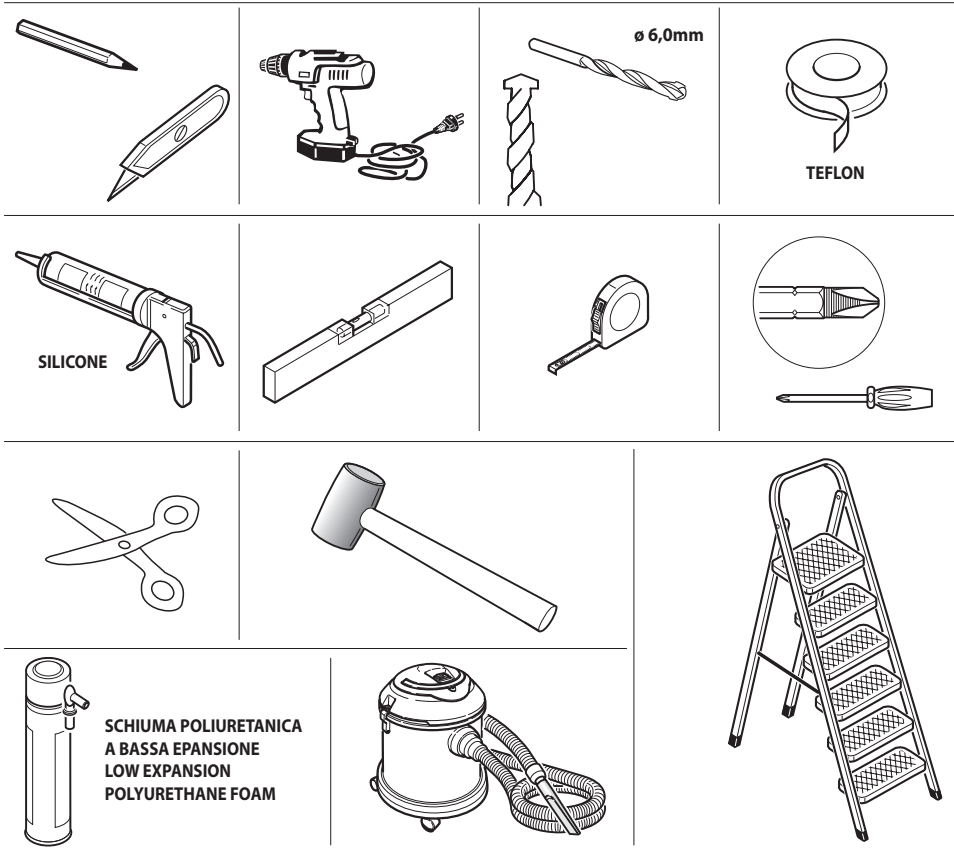



**NOTA IMPORTANTE**



**Prima di iniziare il montaggio chiudere l'acqua.**



**IMPORTANT NOTE**



**Close water taps before starting with assembly.**

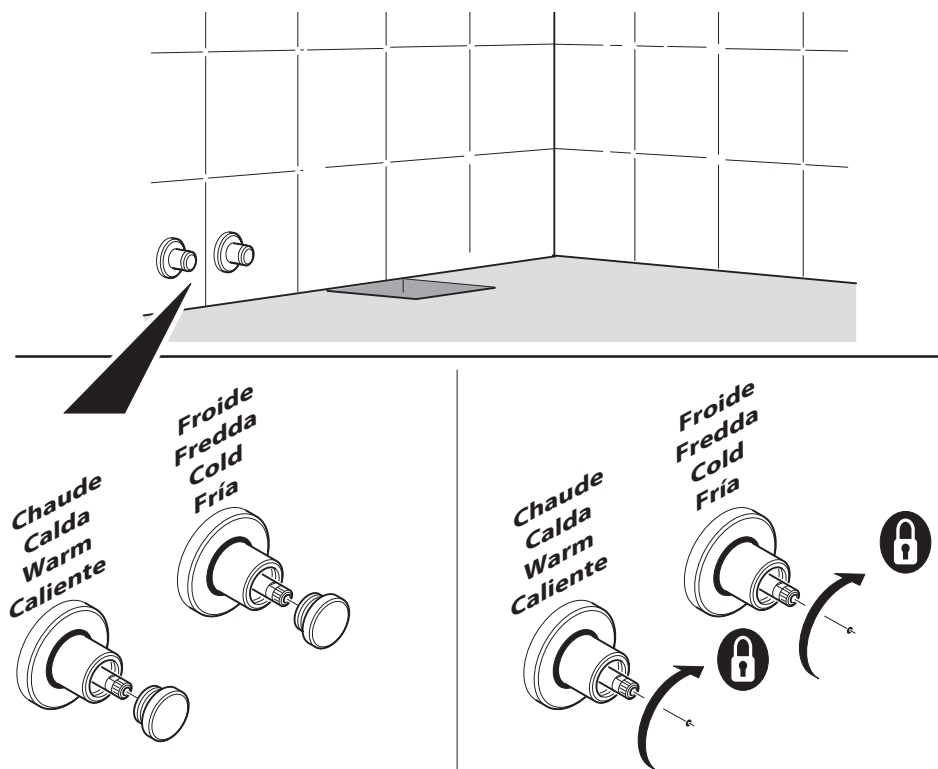

**NOTA IMPORTANTE**  
**IMPORTANT NOTE**

**Verificare che il pavimento e lo scasso siano corrette  
(vedere scheda di pre-installazione)**

***Check that the floor and trenching are correct  
(see pre-installation sheet)***

**Verificare che il pavimento  
sia in piano**

***Check that the floor  
is flat***

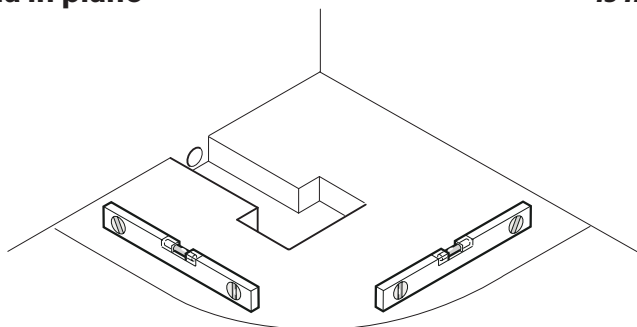

**Piatto spessore 5cm  
5cm thickness tray**

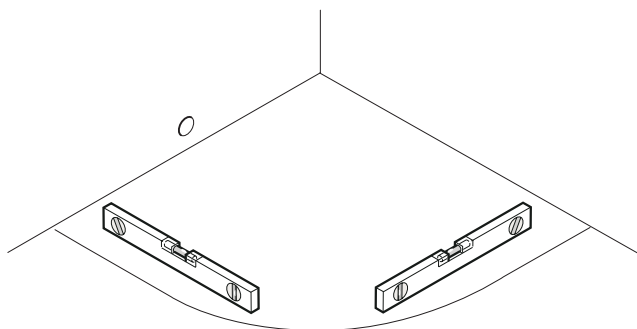

**Piatto spessore 12cm  
12cm thickness tray**

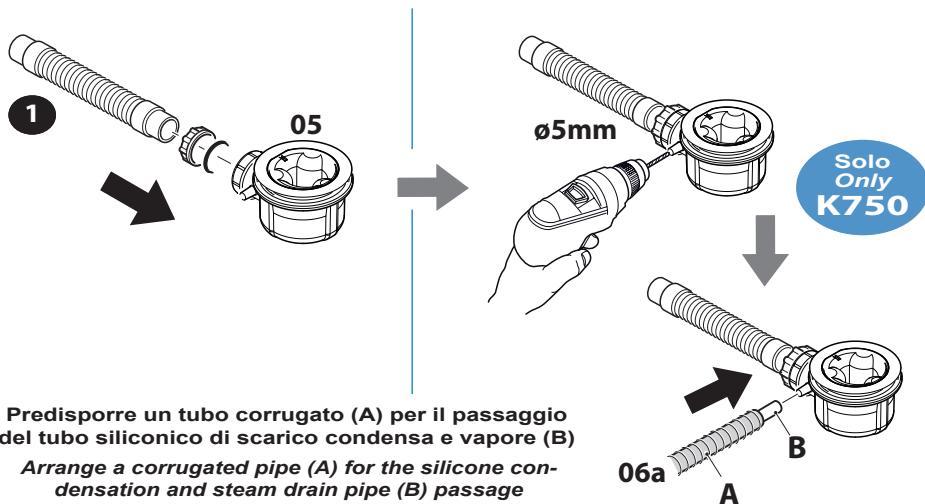

**2**

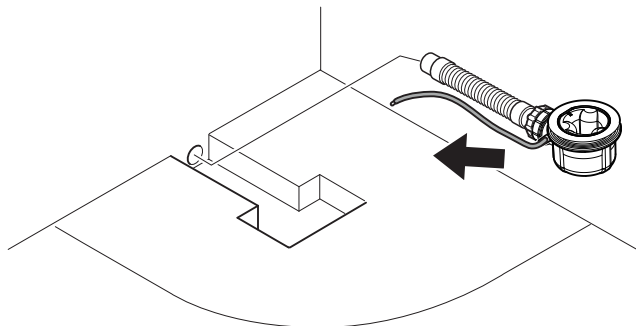

**Piatto spessore 5cm**  
**5cm thickness tray**

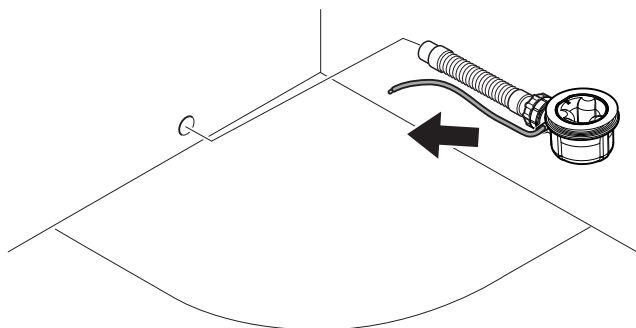

**Piatto spessore 12cm**  
**12cm thickness tray**

Piatto spessore 5cm  
5cm thickness tray

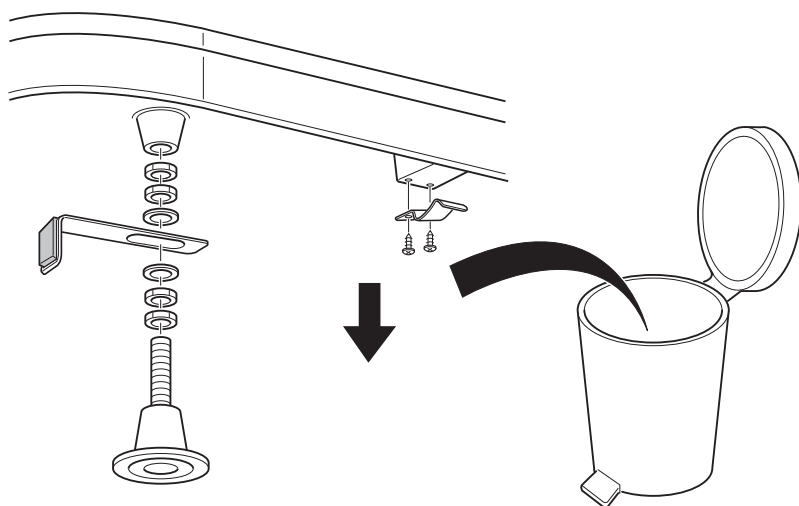
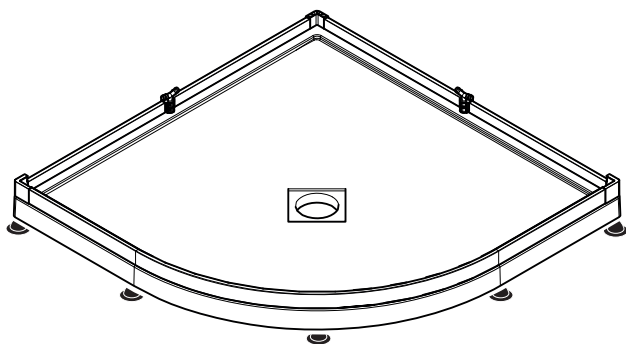

1

Solo  
Only  
K750

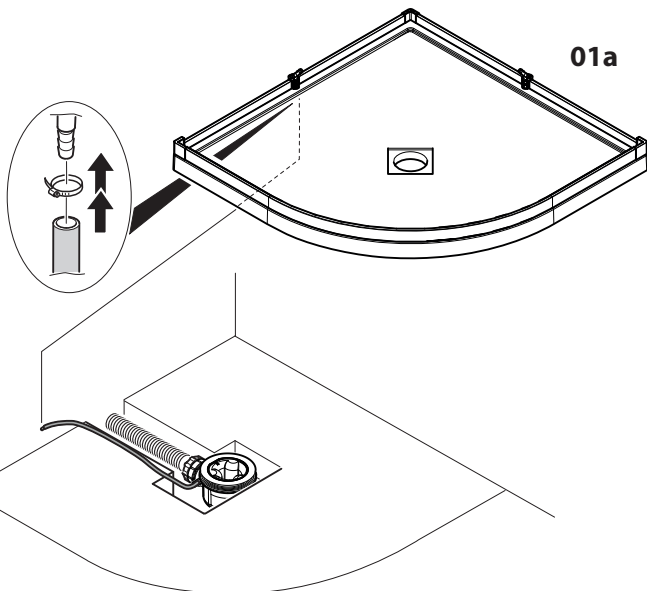

Piatto spessore 5 cm  
5cm thickness tray

2

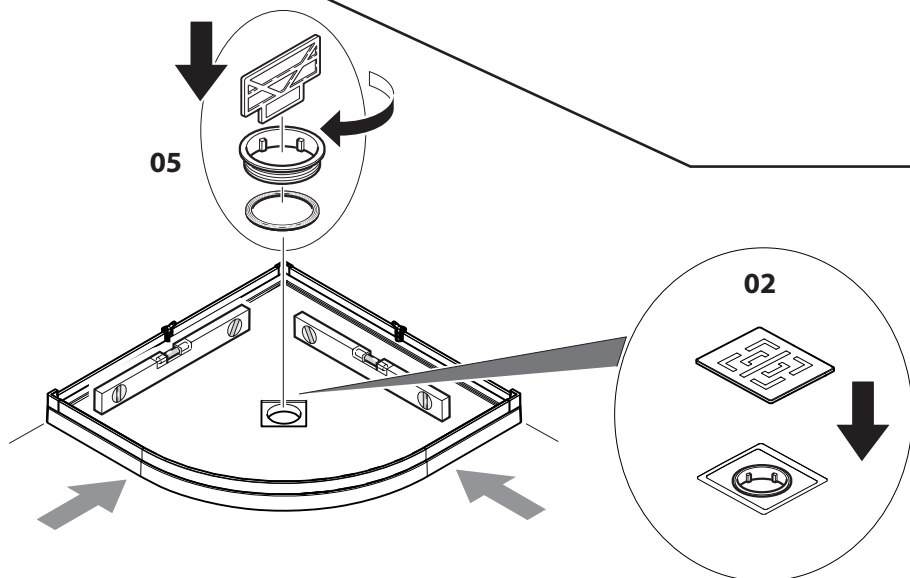

1

01b

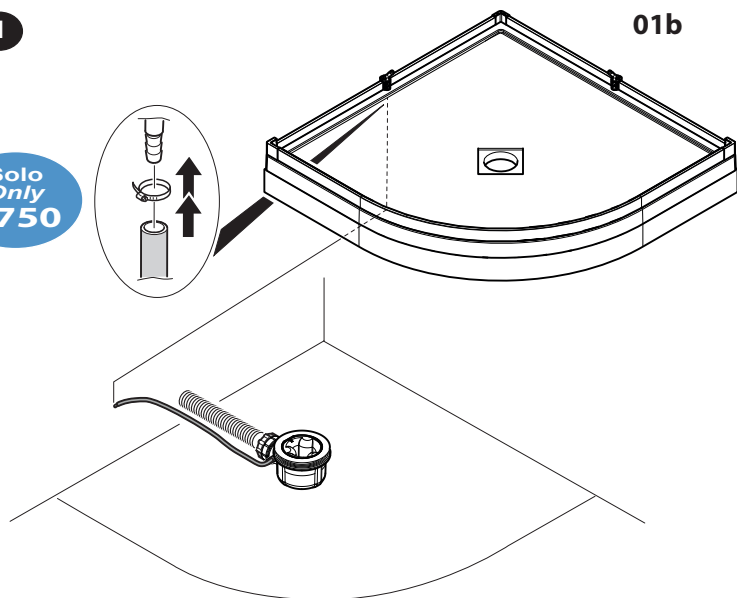
**Solo**  
**Only**  
**K750**

2

05

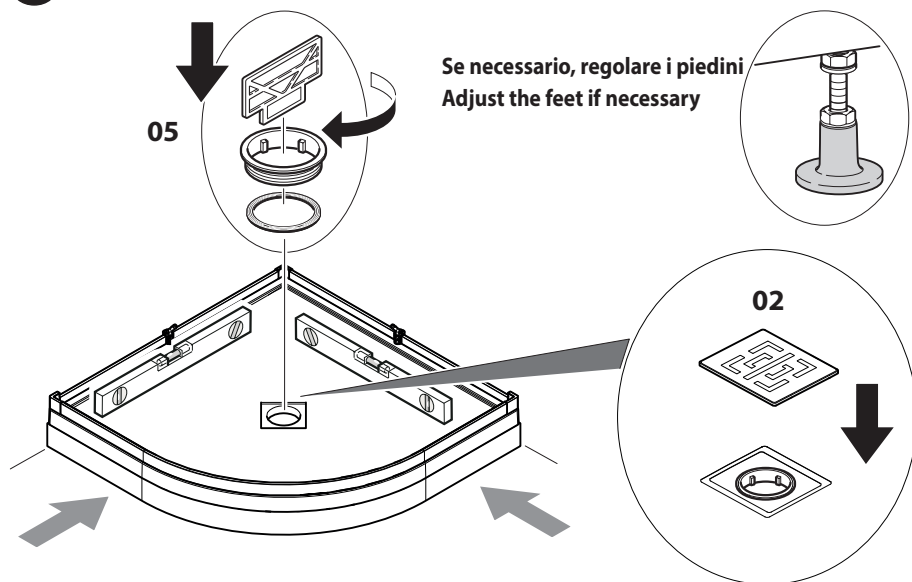
**Se necessario, regolare i piedini**  
**Adjust the feet if necessary**

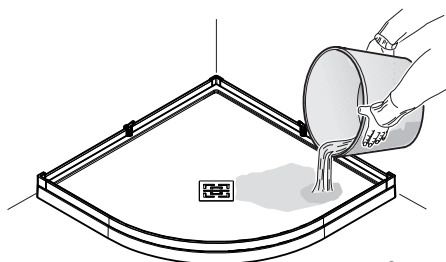

Piatto spessore 5cm  
5cm thickness tray

Prima della posa definitiva verificare la linearità del piatto e il corretto deflusso dell'acqua verso lo scarico.

Before definitive positioning, check the tray linearity and the correct outflow of water towards the drain.

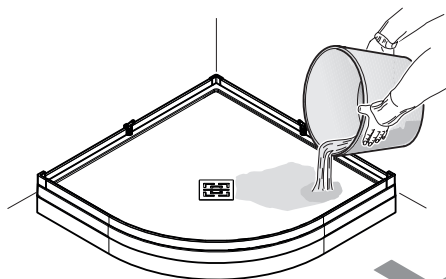
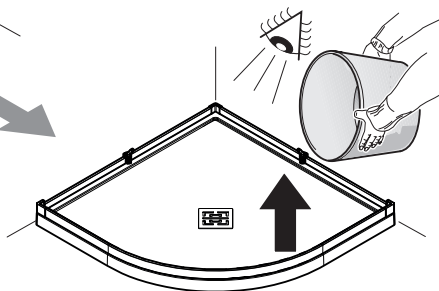

Piatto spessore 12cm  
12cm thickness tray

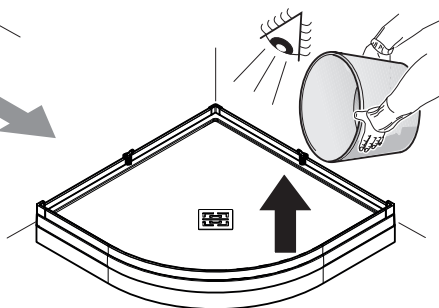
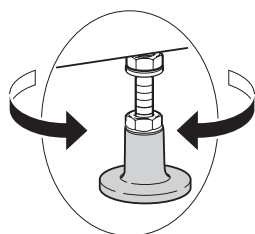

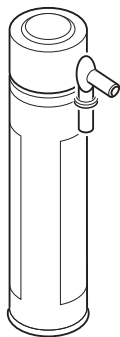

SCHIUMA POLIURETANICA  
A BASSA EPANSIONE  
LOW EXPANSION  
POLYURETHANE FOAM

Piatto spessore 5cm  
*5cm thickness tray*

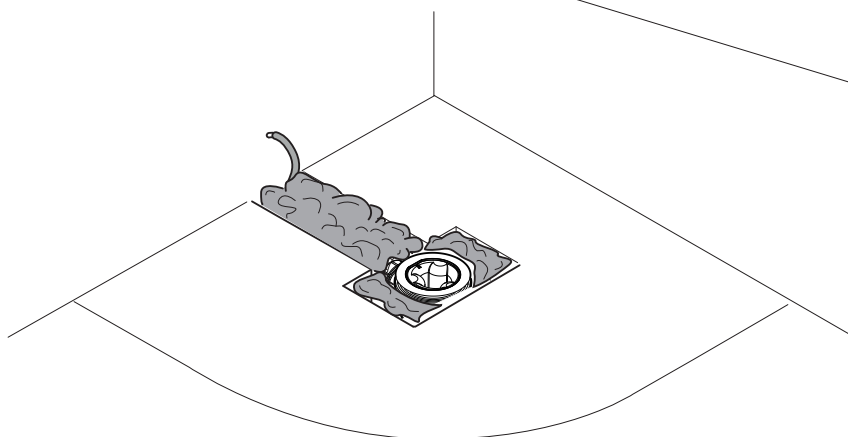
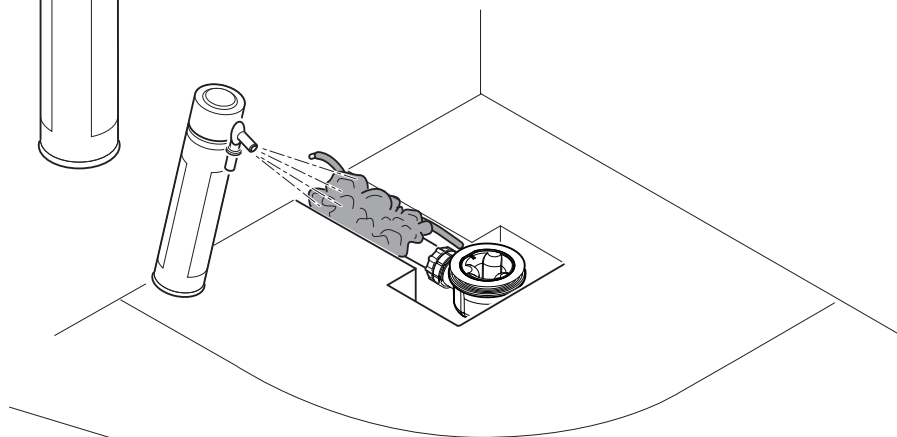

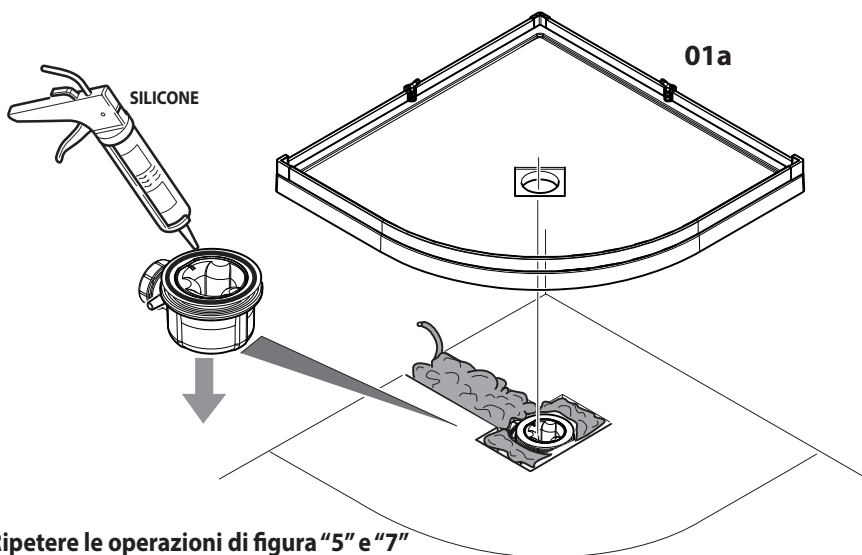

Ripetere le operazioni di figura "5" e "7"  
*Repeat the operations of figure "5" and "7"*

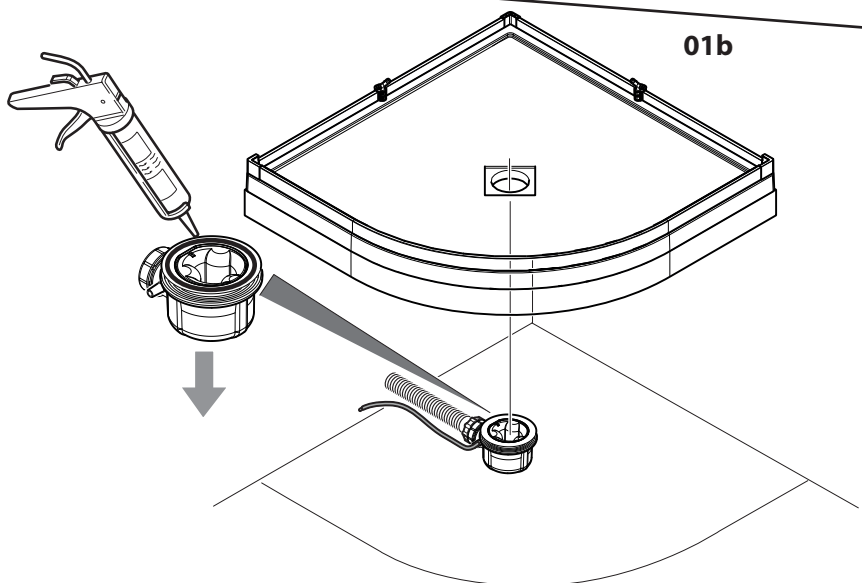

Ripetere le operazioni di figura "6" e "7"  
*Repeat the operations of figure "6" and "7"*

**Siliconare con attenzione  
il profilo del piatto  
alla parete**

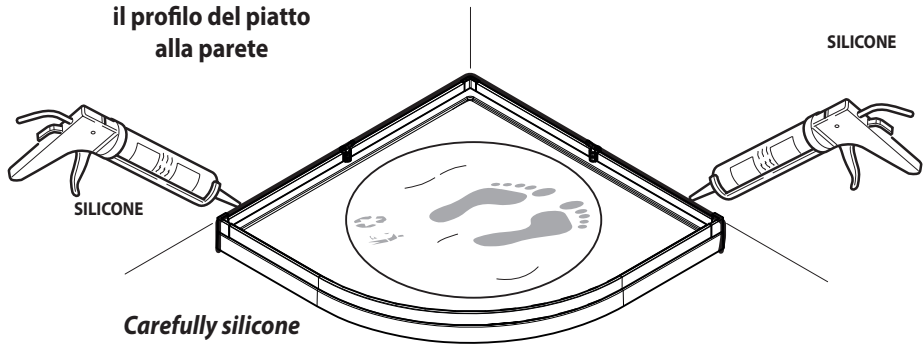

**Carefully silicone  
the profile of the tray  
to the wall**

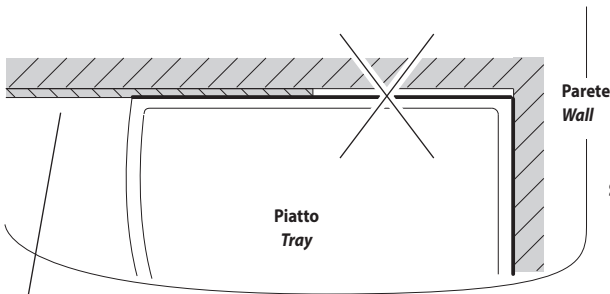

**Assicurarsi che non ci siano  
spessori (esempio: zoccolini)  
che possono impedire  
l'aderenza del piatto  
alla parete.**

**Make sure there are no shims  
(eg. skirting boards) that can  
prevent the tray  
from adhering to the wall.**

**Zoccolino  
Skirting**

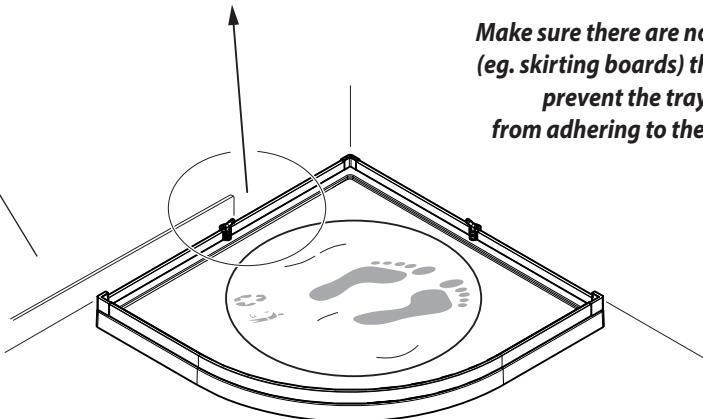

K500

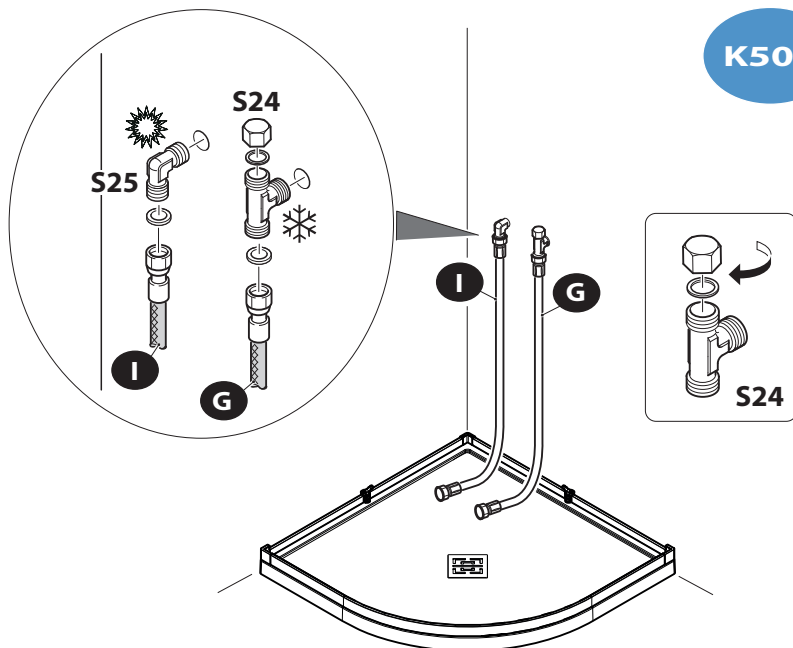

K750

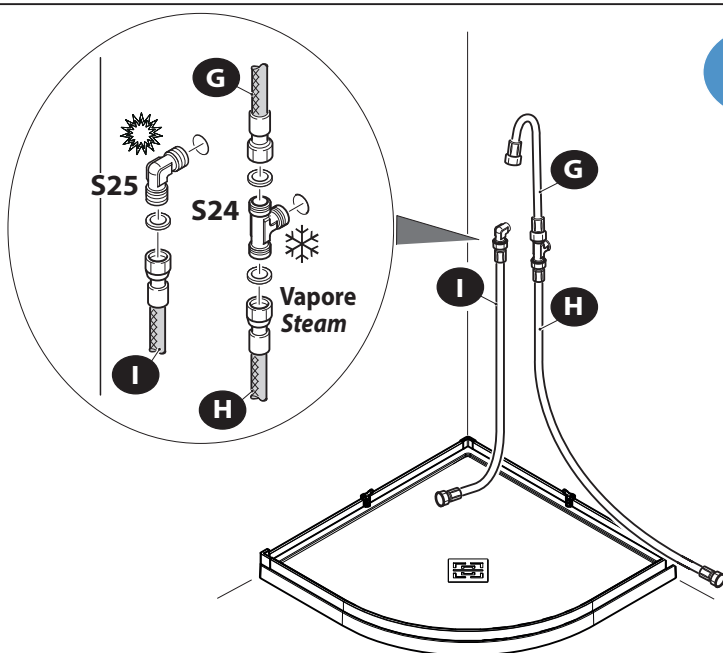

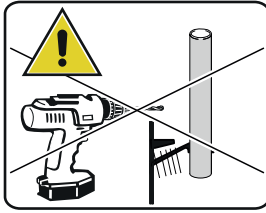
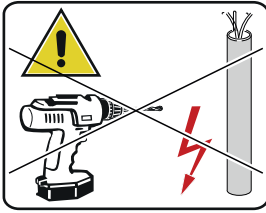

Solo  
Only  
K750

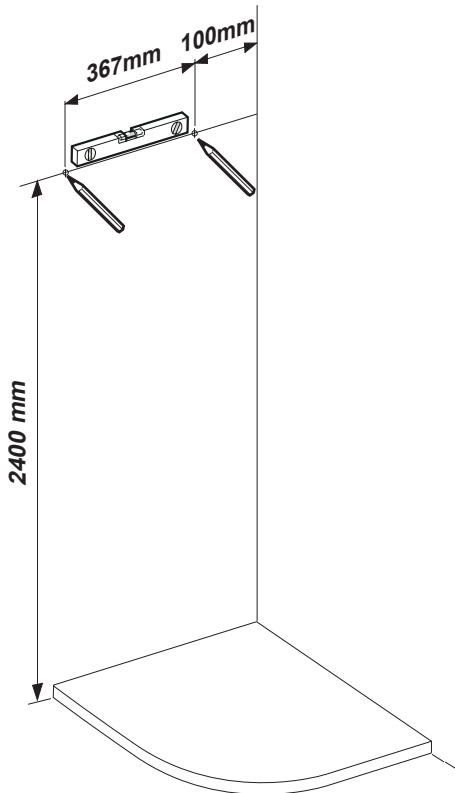
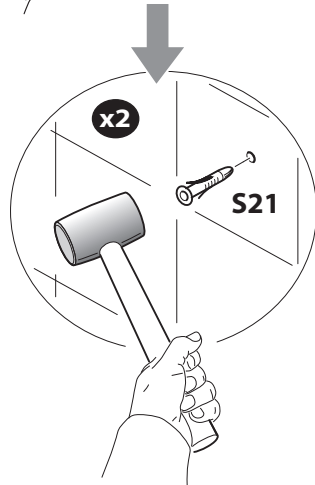
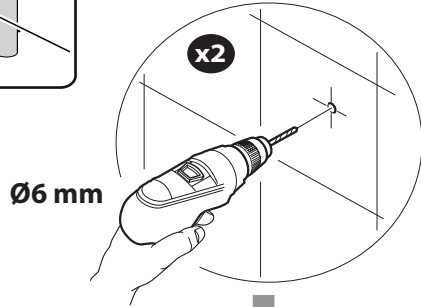

Solo  
Only  
K750

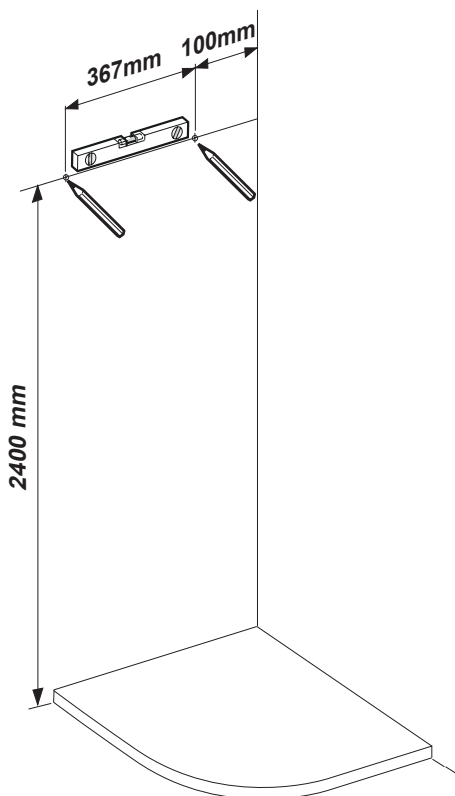
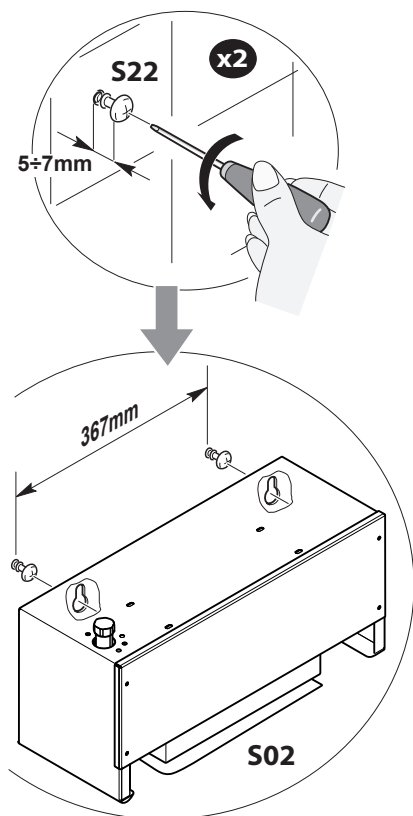

Solo  
Only  
K750

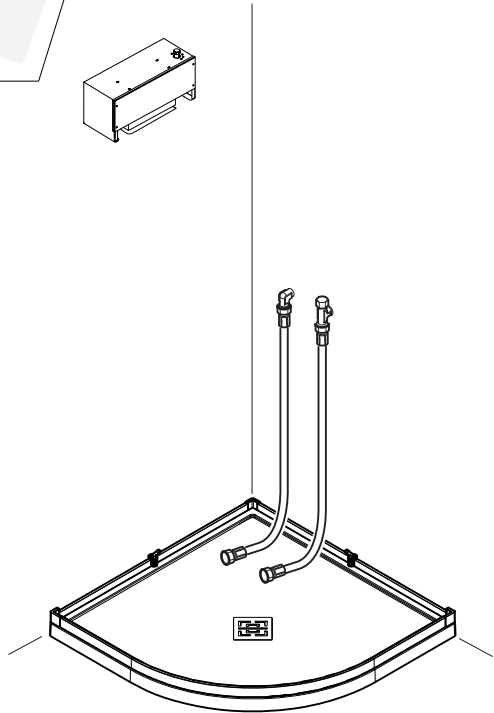
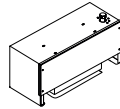
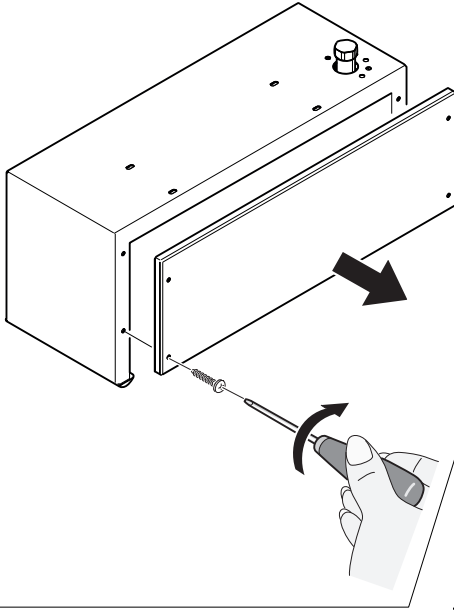

Solo  
Only  
K750

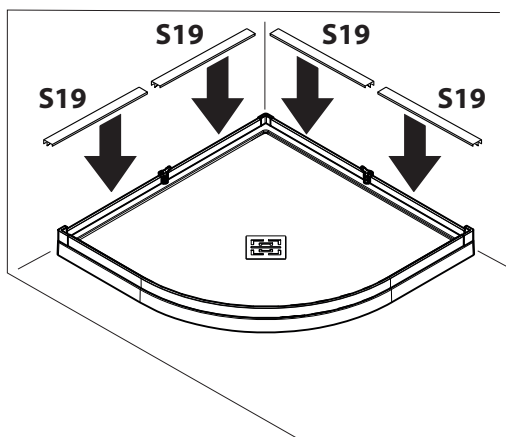
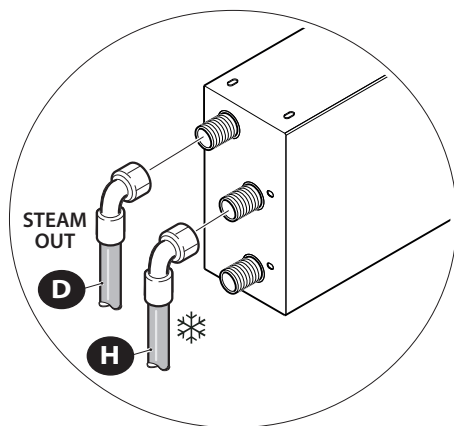
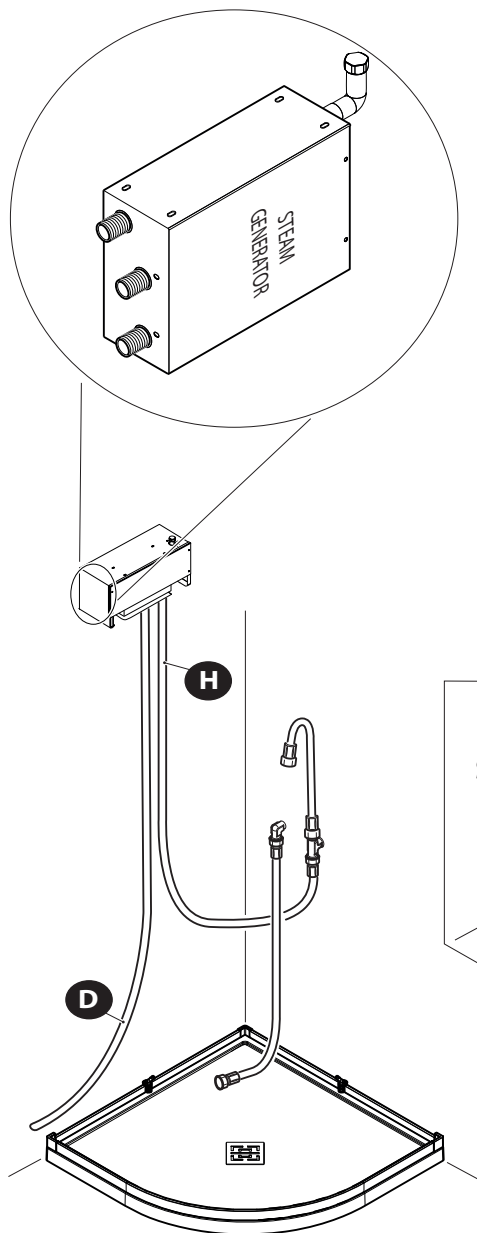

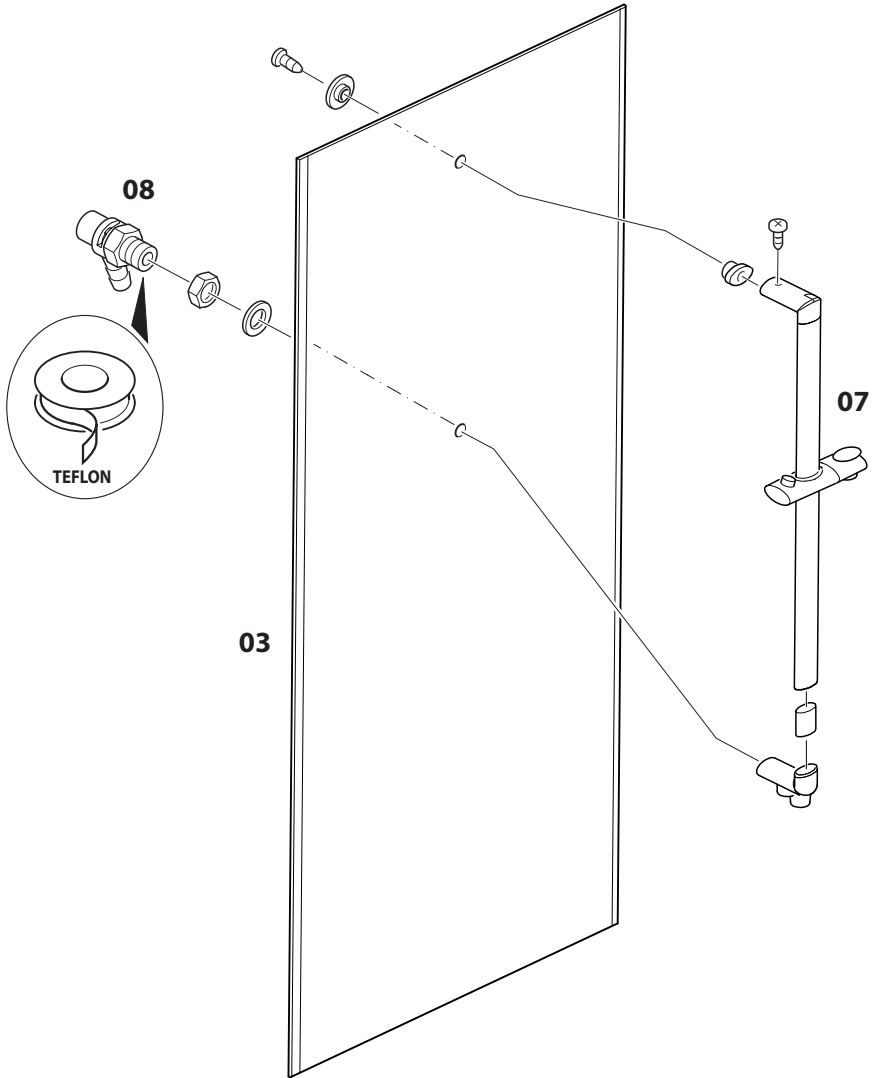

Solo  
Only  
K750

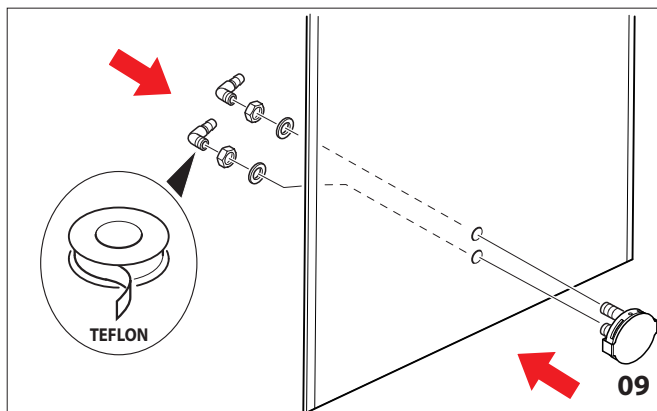
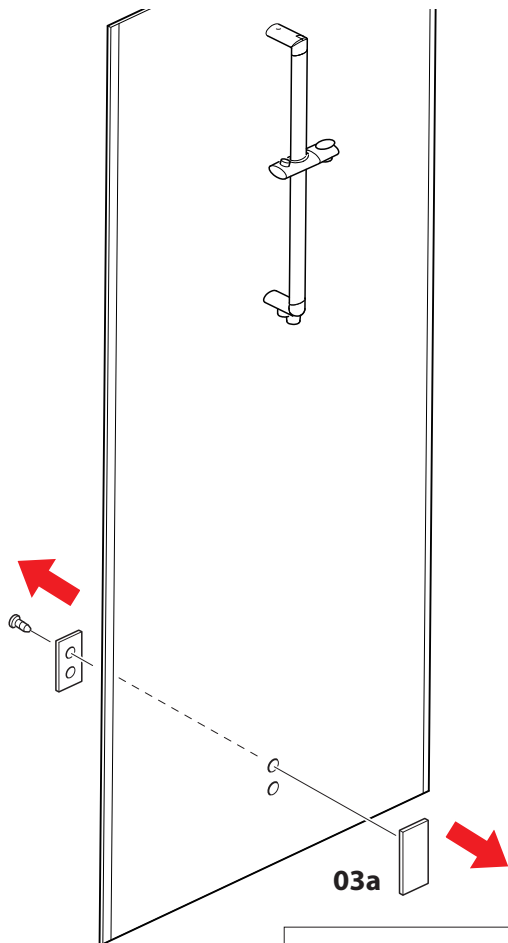

Solo  
Only  
K750



**ATTENZIONE**  
**WARNING**



**PRIMA DI CONNETTERE  
ELETTRICAMENTE LA CABINA DOCCIA  
ASSICURARSI CHE NON VI SIA TENSIONE  
NEI CAVI PROVENIENTI DALL'IMPIANTO.**

***BEFORE ELECTRICALLY CONNECTING  
THE SHOWER CABIN, MAKE SURE  
THERE'S NO VOLTAGE IN THE CABLES  
COMING FROM THE SYSTEM.***

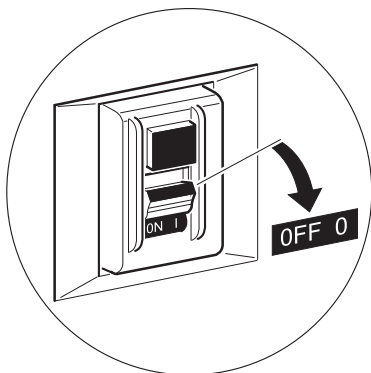

**A. Cavo di alimentazione**  
**Power cable**

**B. Cavo equipotenziale**  
**Equipotential cable**

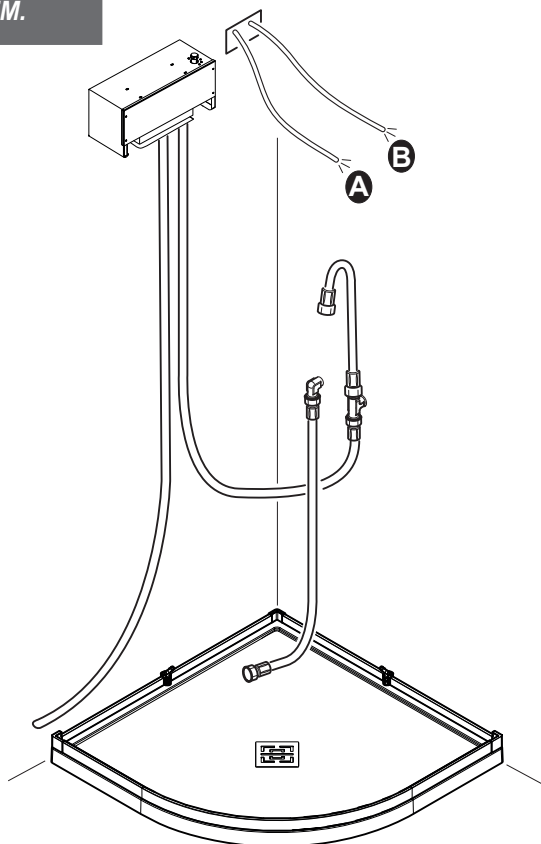

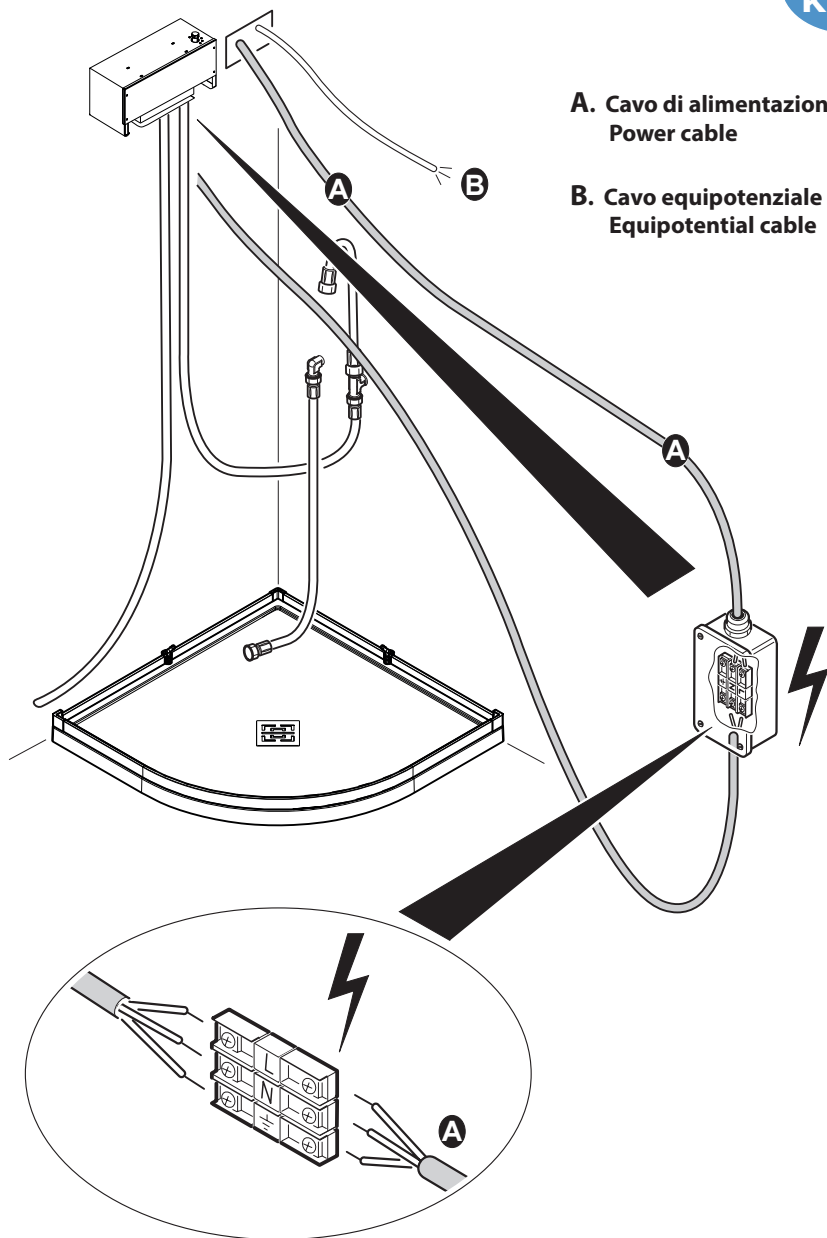

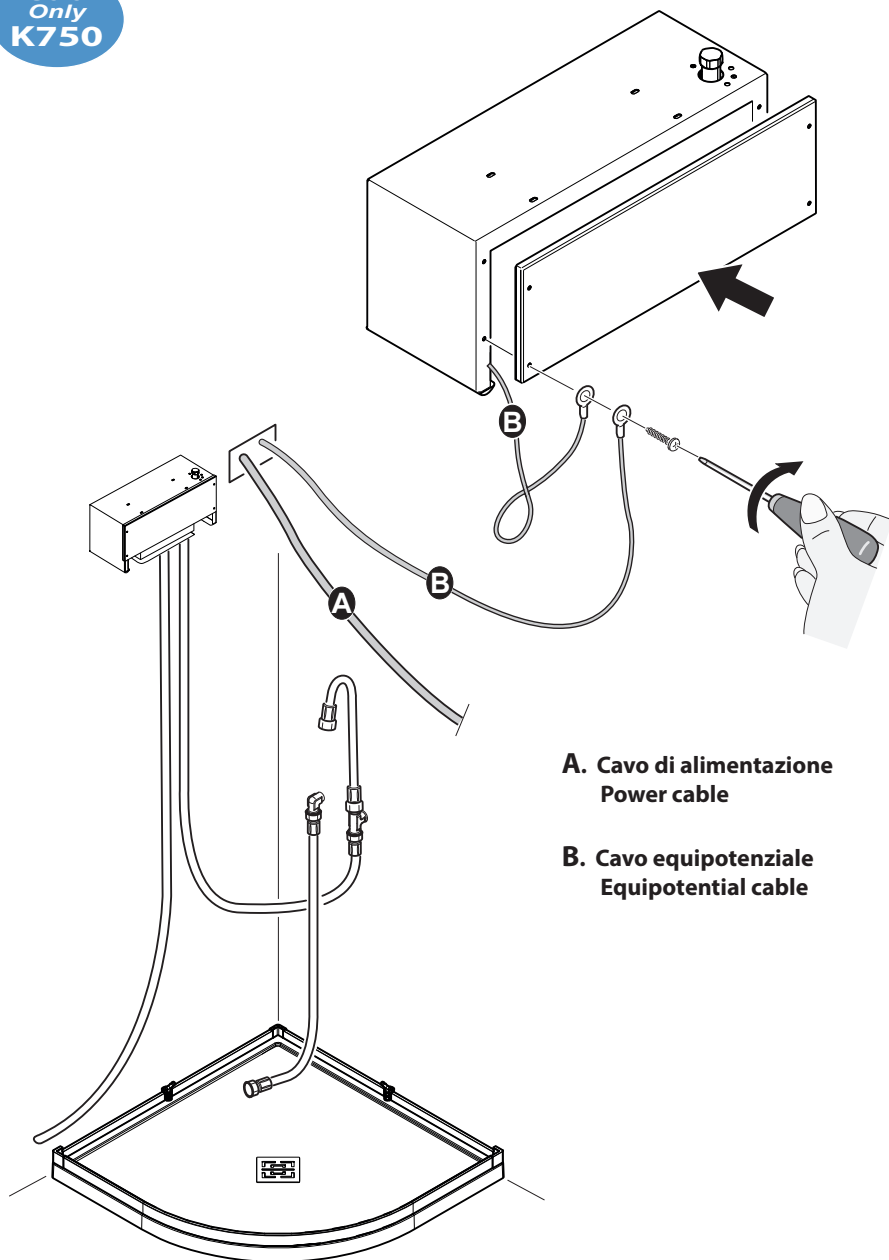
Solo  
Only  
K750

Solo  
Only  
K750

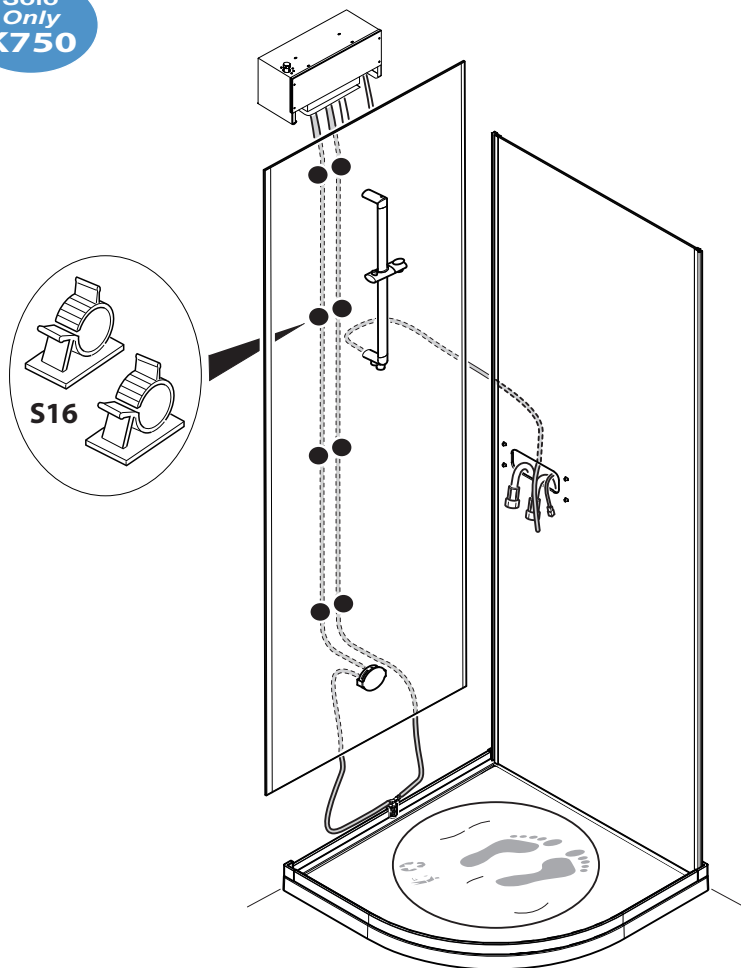

Per facilitare il collegamento delle tubazioni, utilizzare le fascette (S16) già presenti sul retro del pannello (lato corto).

In figura sono rappresentati i punti di fissaggio, bloccare i tubi sulle fascette (vedere pagina seguente).

To ease connection of the pipes, use the clamps (S16) already located on the back of the panel (short side).

The fastening points are shown in the figure, lock the pipes on the clamps (see the next page).

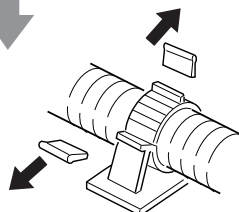
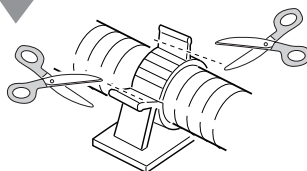
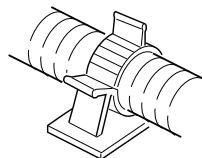
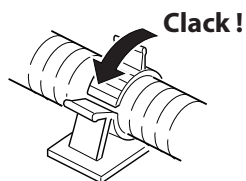
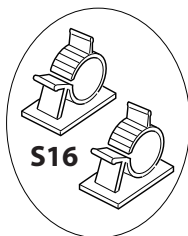
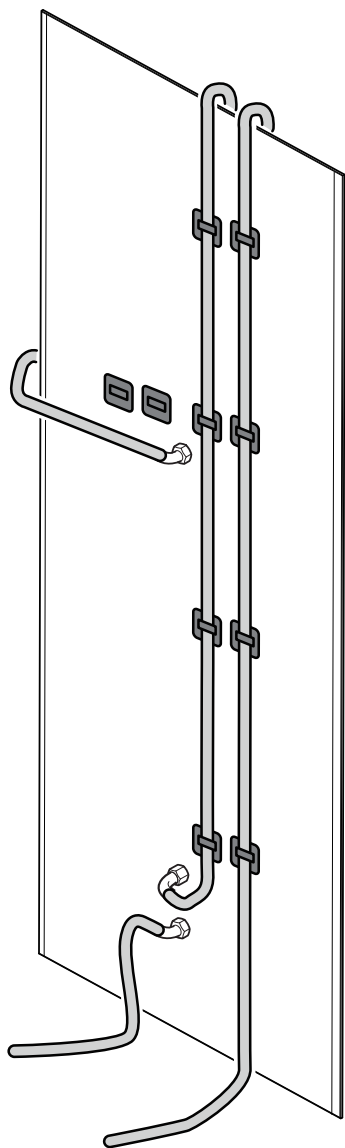
Solo  
Only  
K750

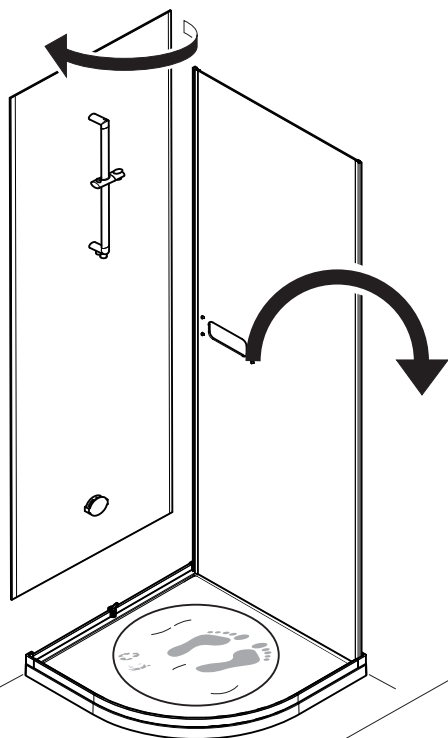

**REVERSIBILITA'**  
**REVERSIBILITY**

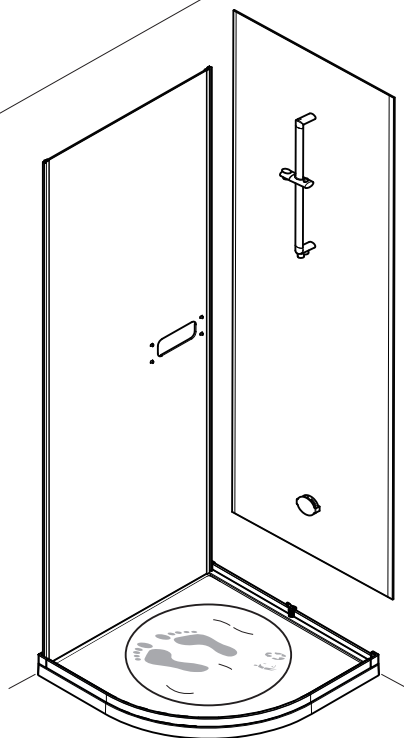

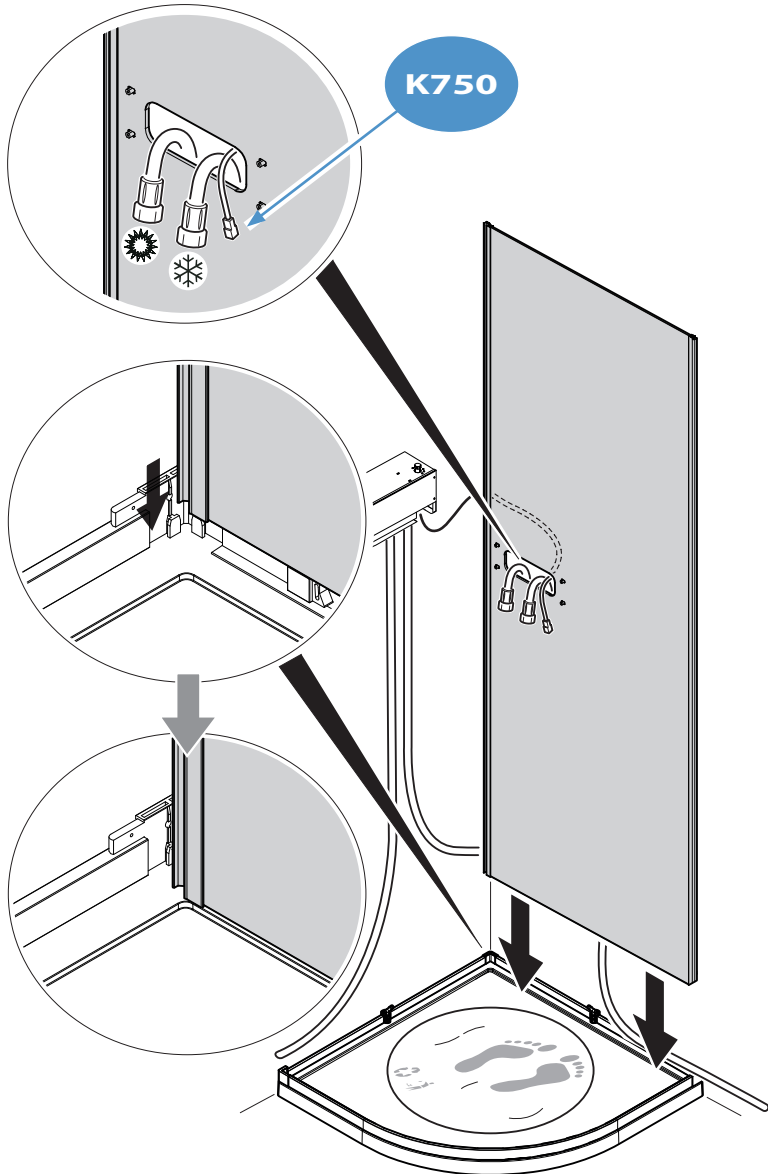

K500

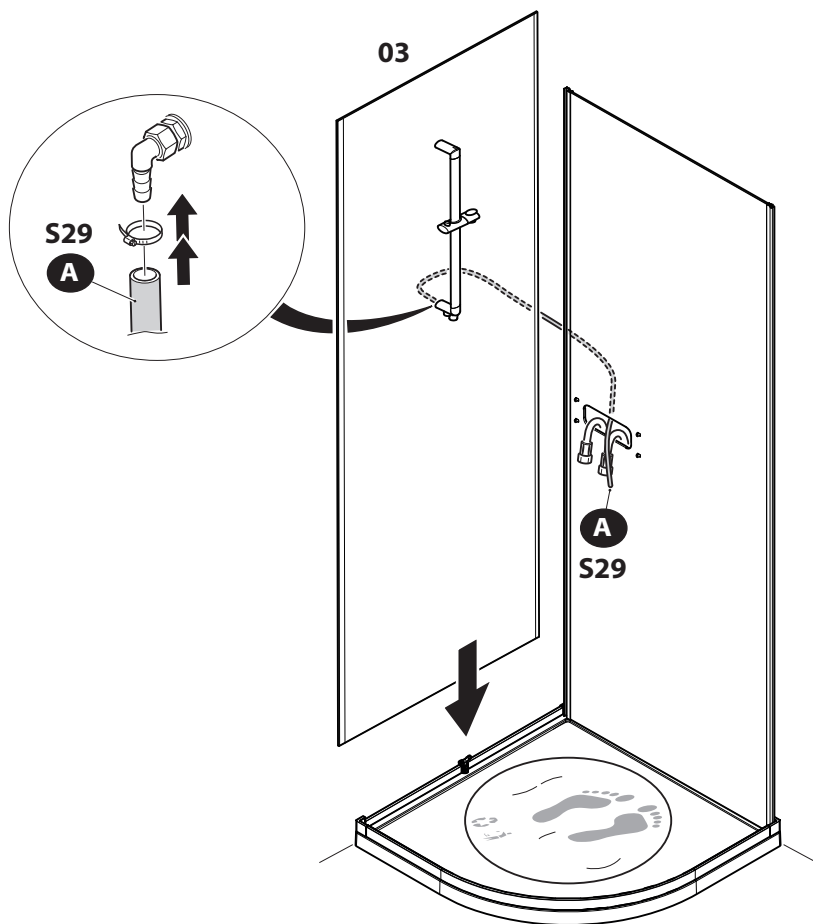

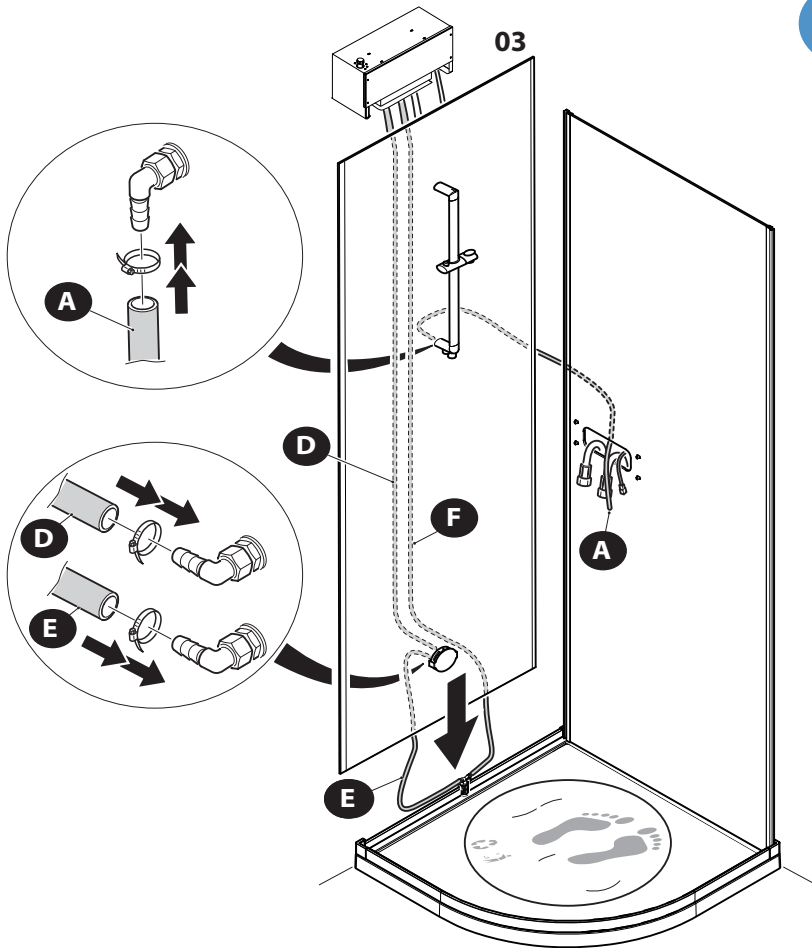

**Verificare che i tubi del vapore (D - E - F)  
non siano troppo lunghi; se necessario tagliarli.  
Dare della pendenza (~1%) al tubo di scarico condensa (E).**

**Check that the steam pipes (D - E - F)  
are not too long; cut them if necessary.  
Incline (~1%) the condensation drain pipe (E).**

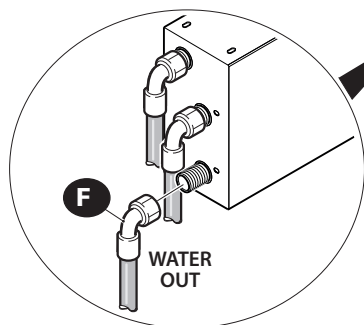

**Verificare che i tubi del  
vapore (D - E - F)  
non siano troppo lunghi; se  
necessario tagliarli.  
Dare della pendenza (~1%) al  
tubo di scarico condensa (E).**

**Check that the steam pipes  
(D - E - F)  
are not too long; cut them if  
necessary.**

**Incline (~1%) the  
condensation drain pipe (E).**

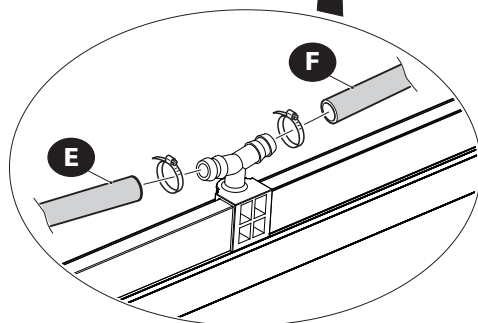
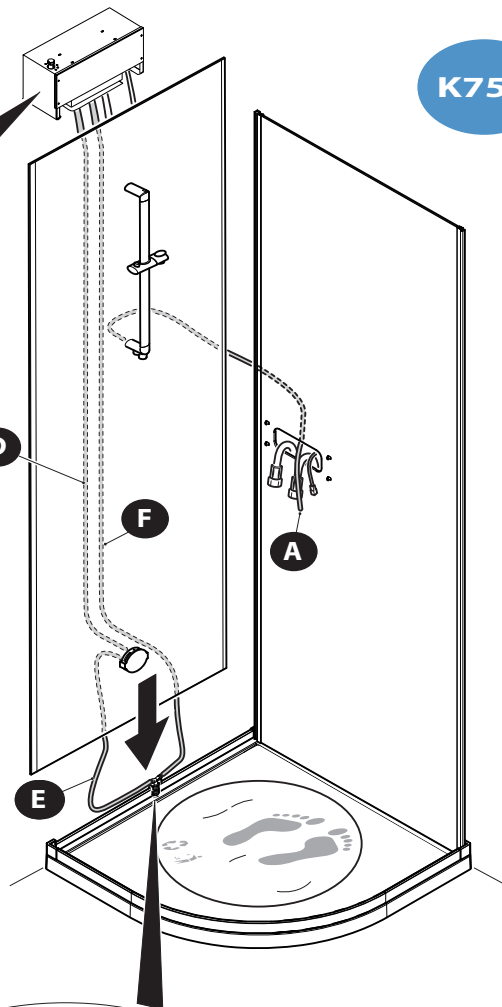

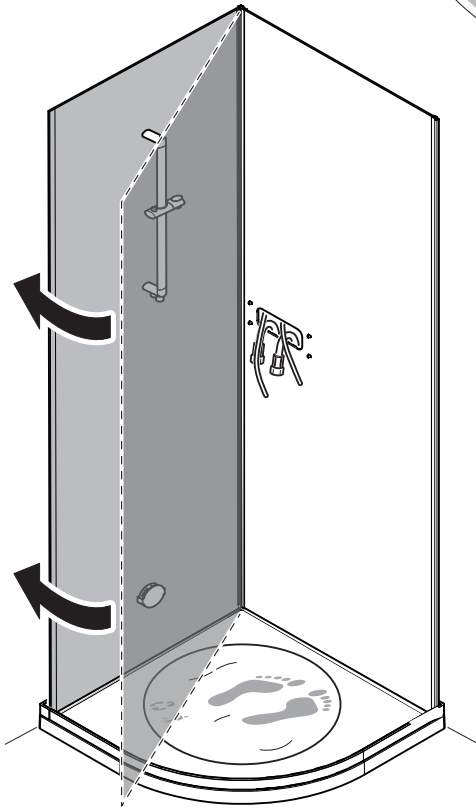
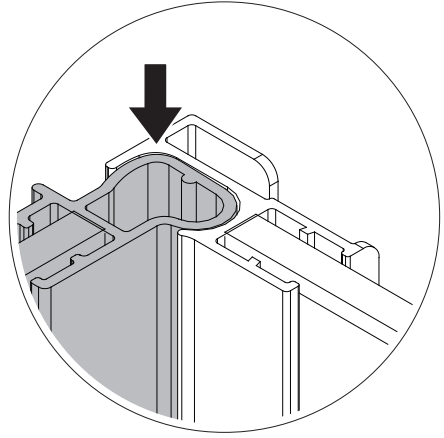

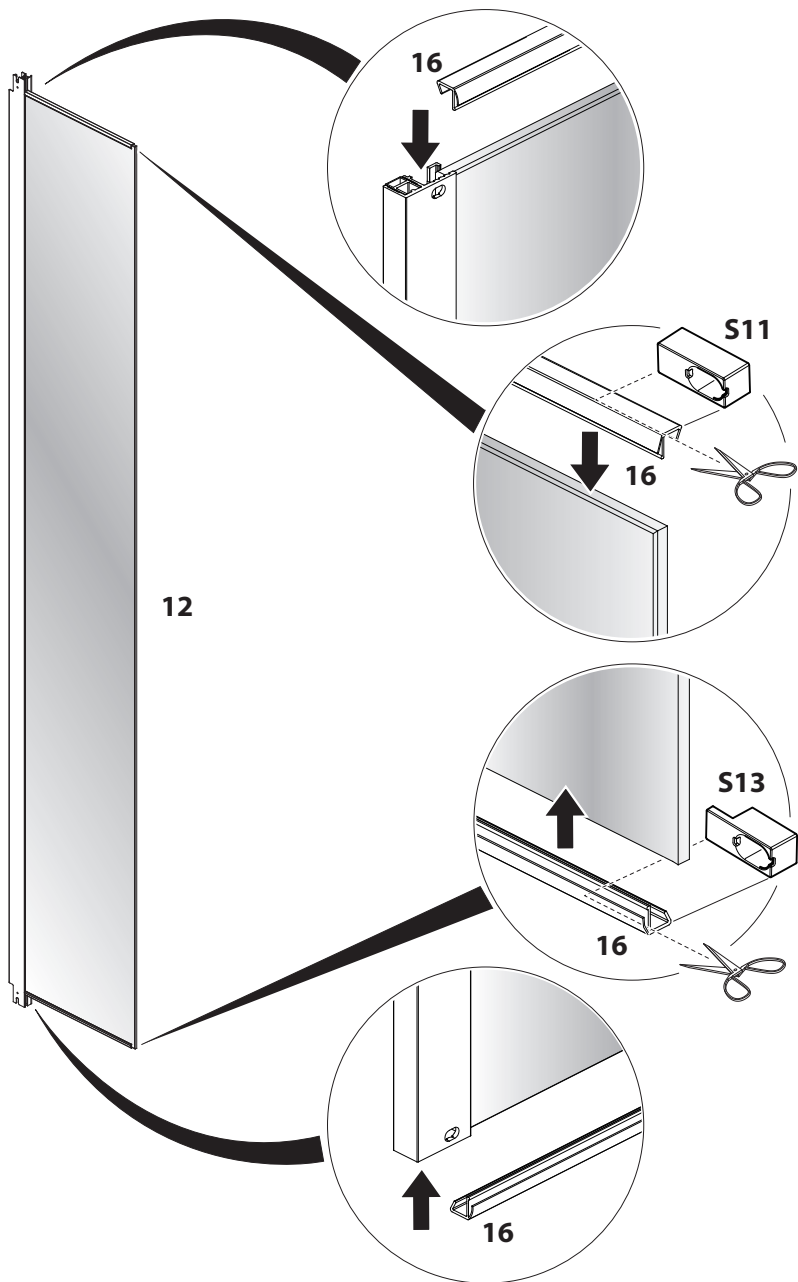

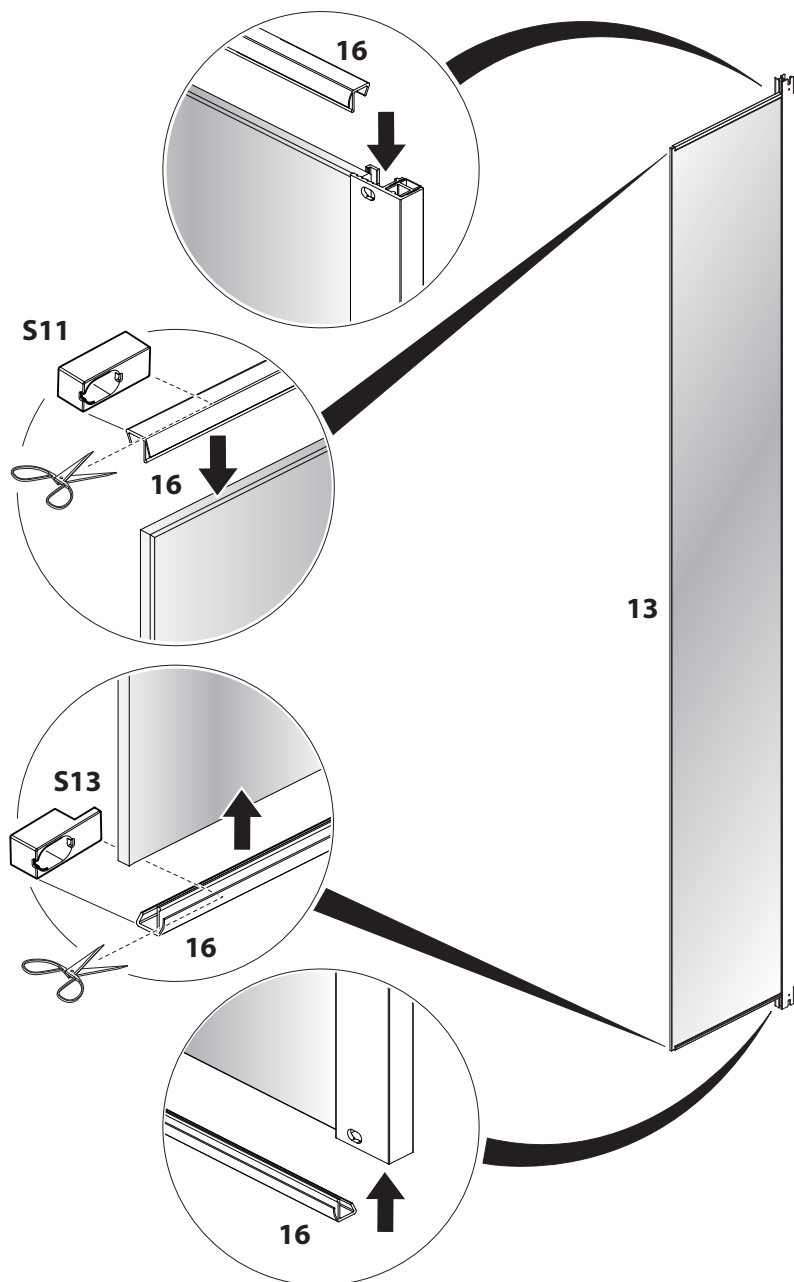

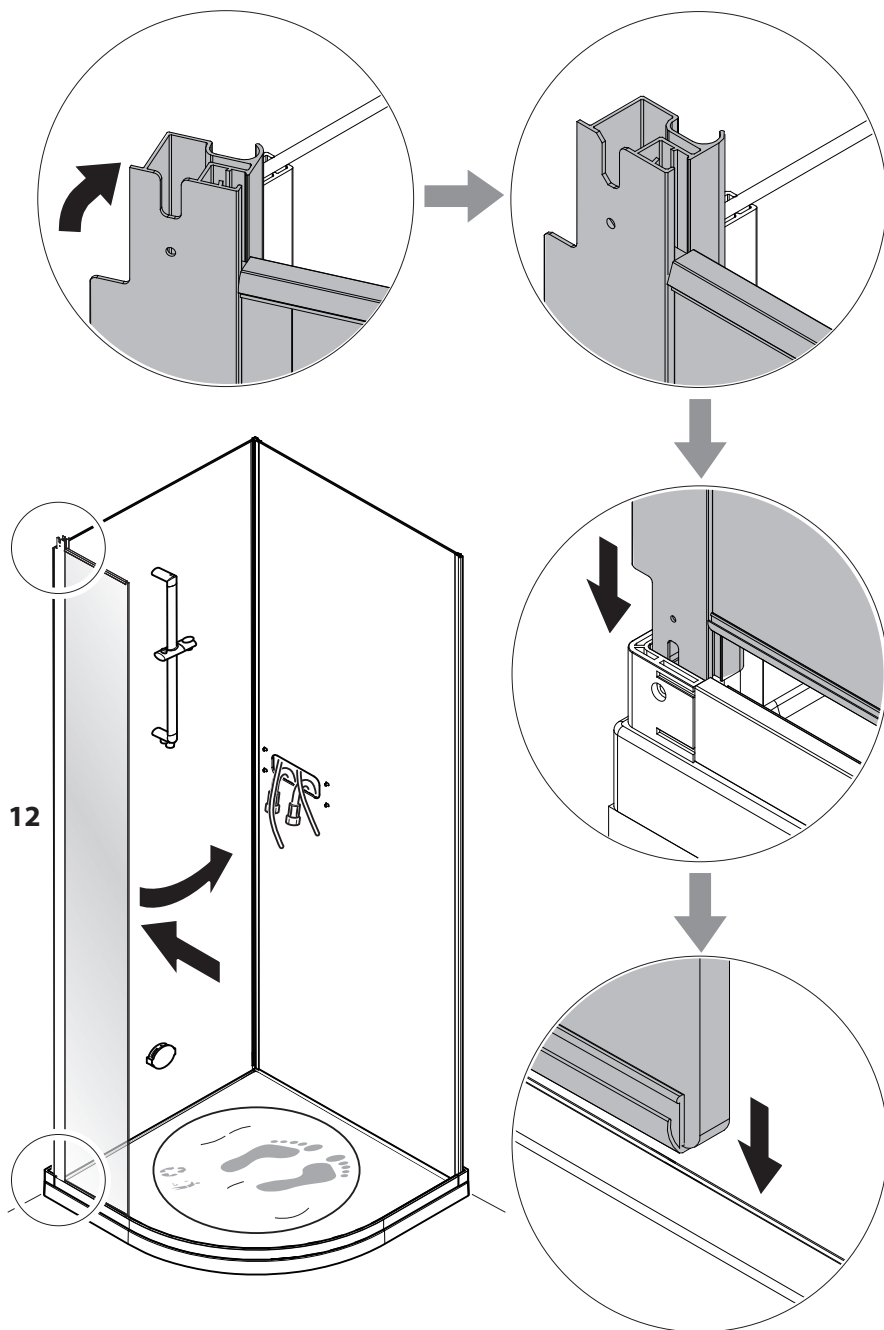

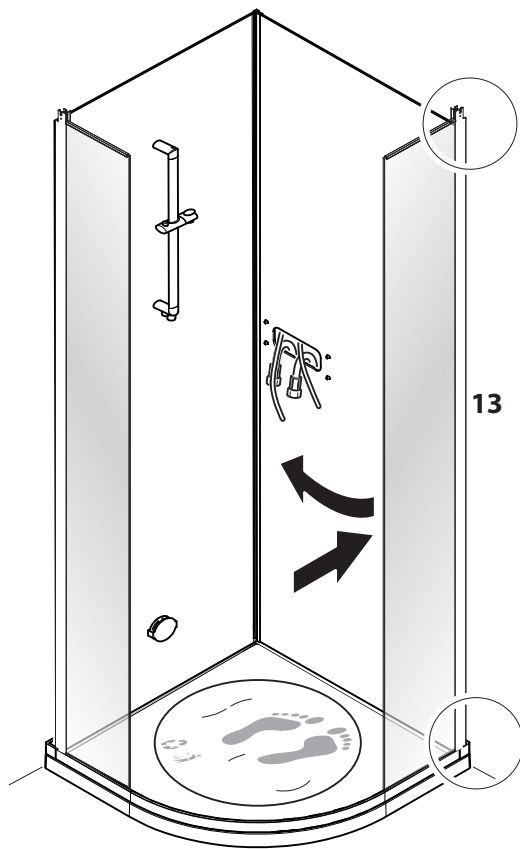
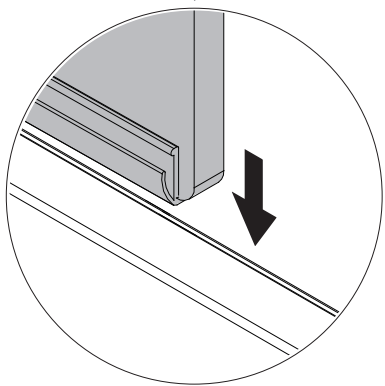
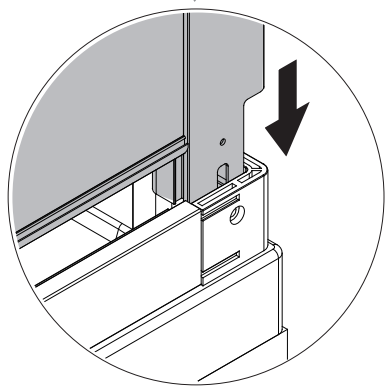
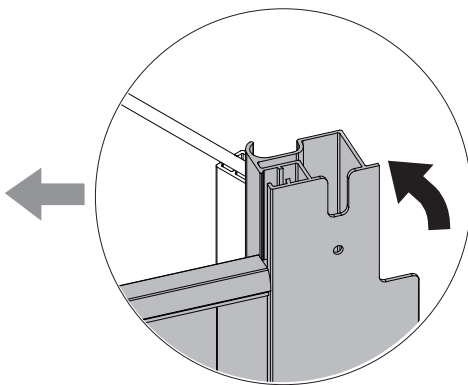
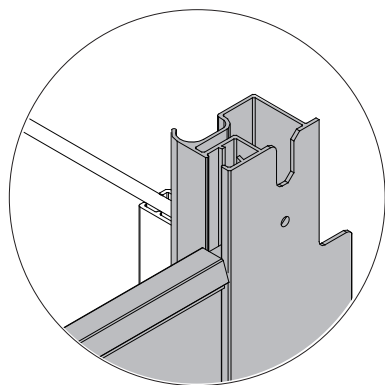

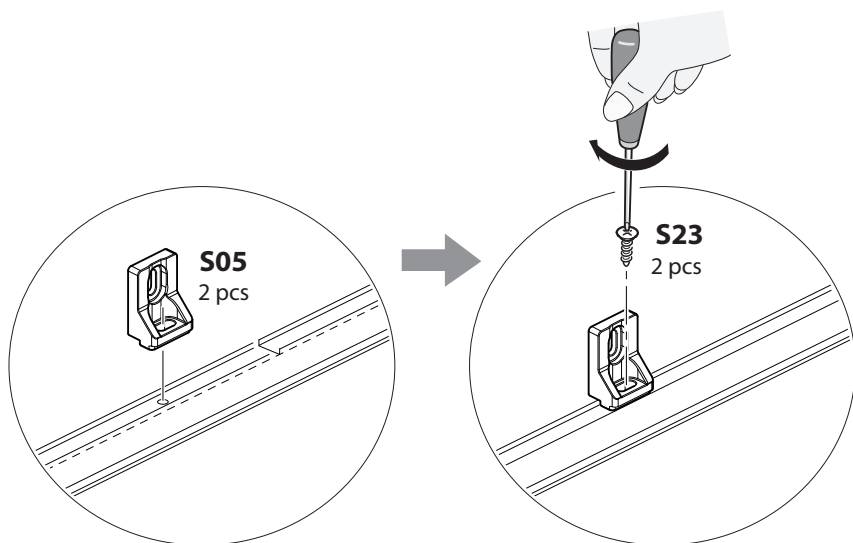

**Avvitare senza serrare**  
**Screw without tightening**

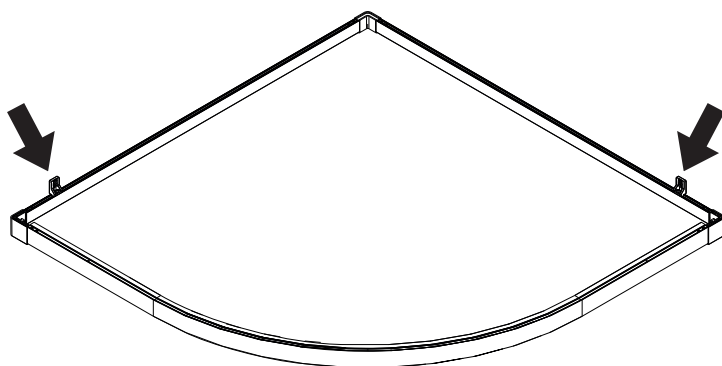

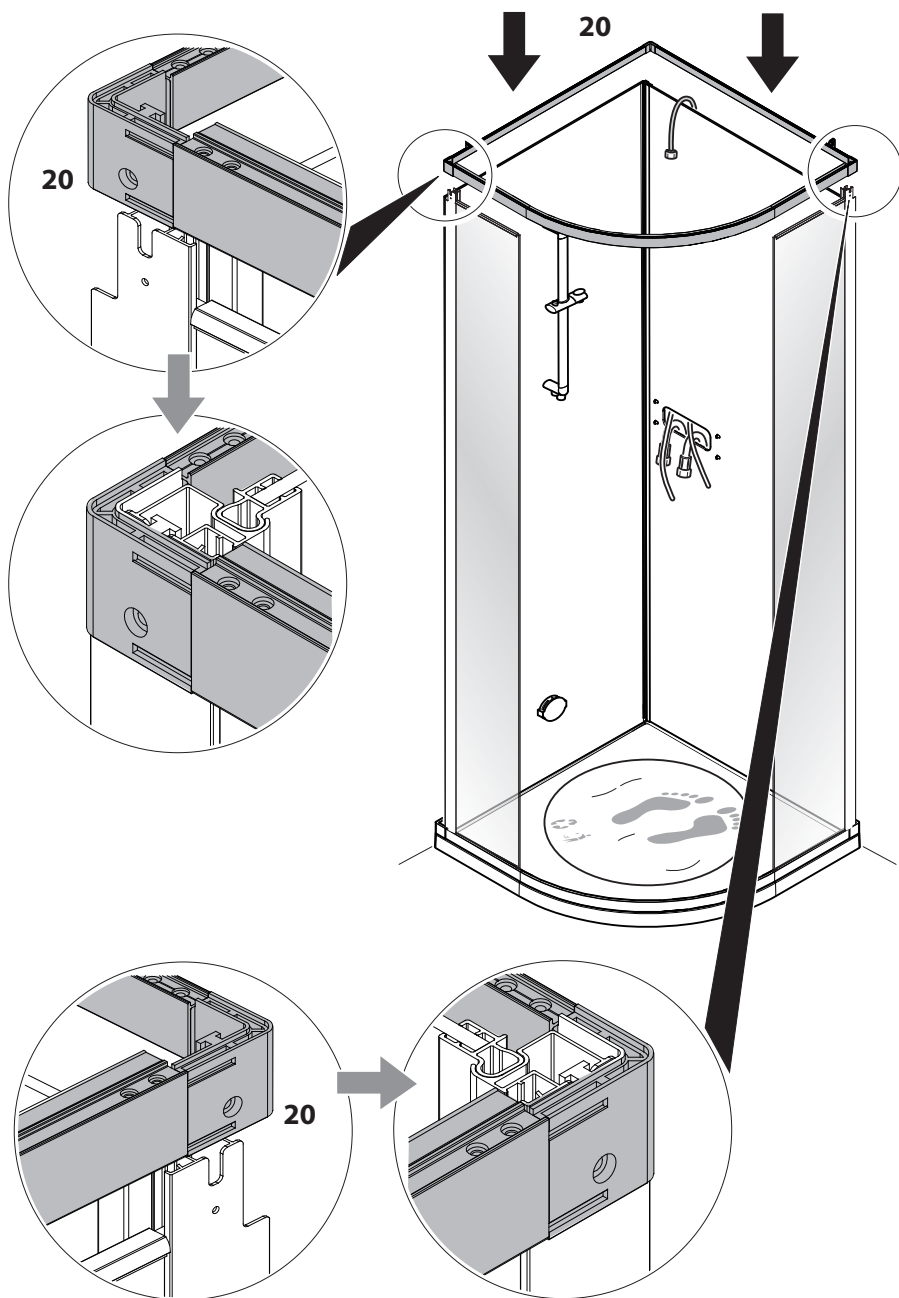

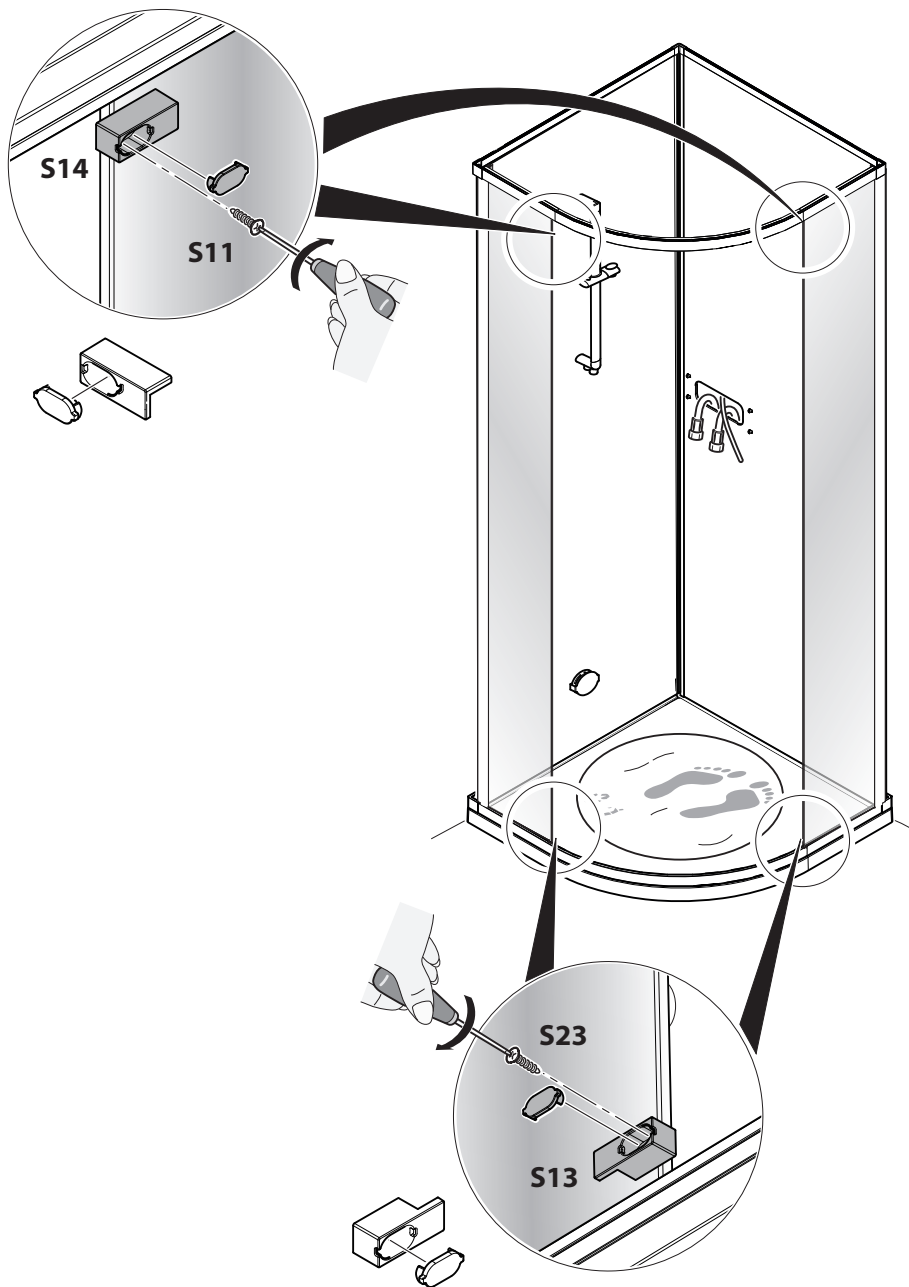

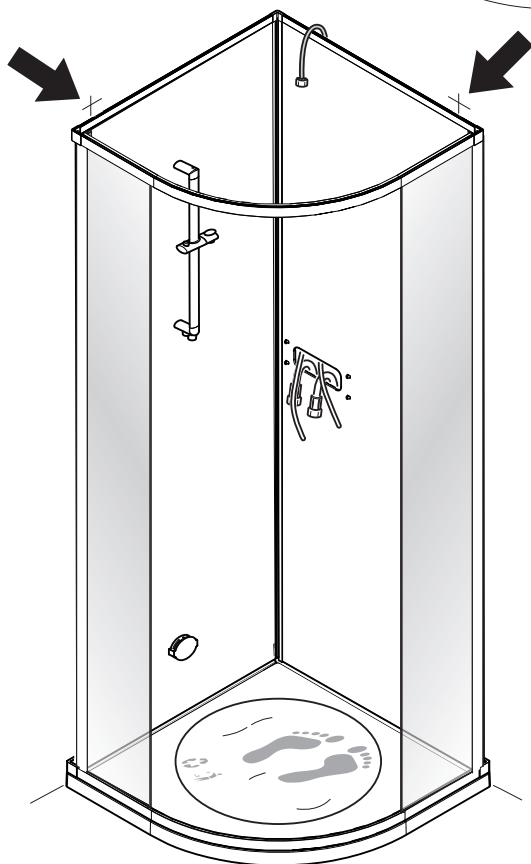
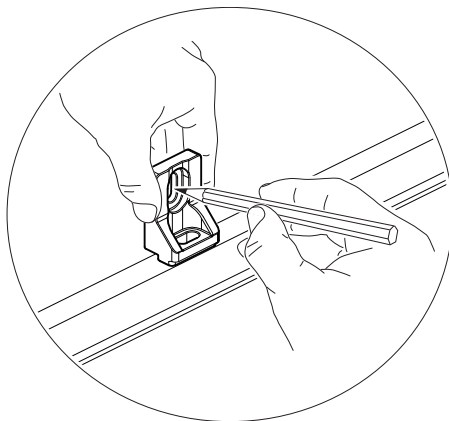
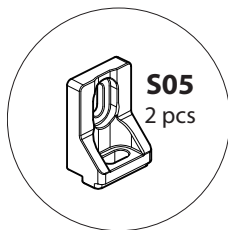

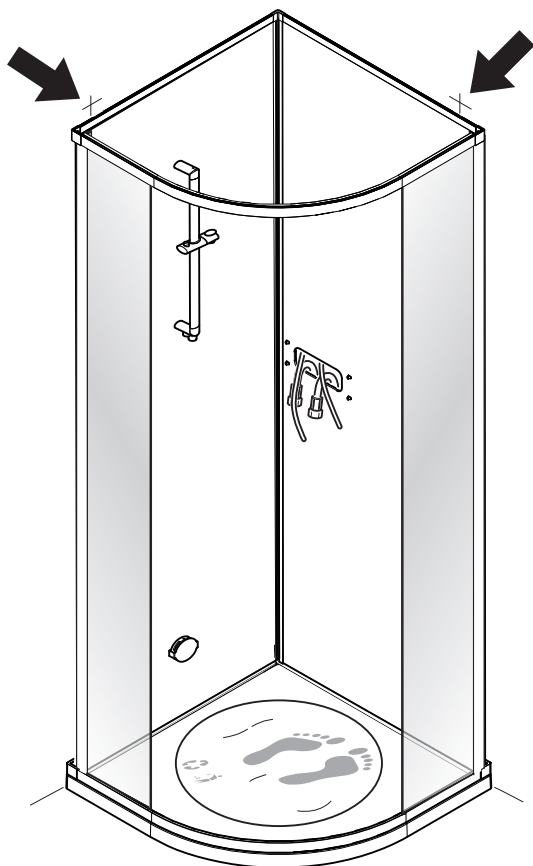
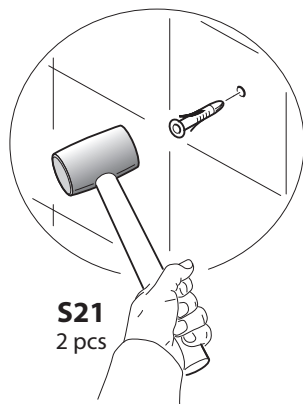
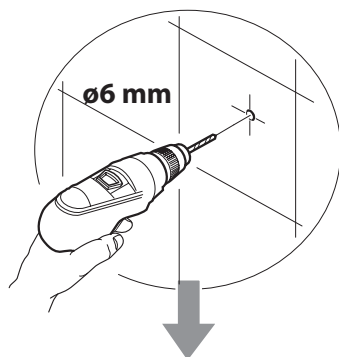
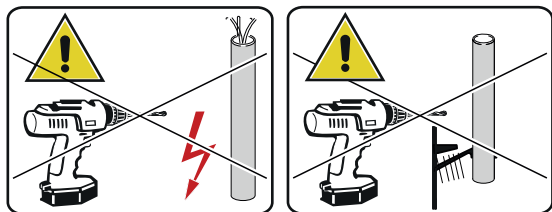

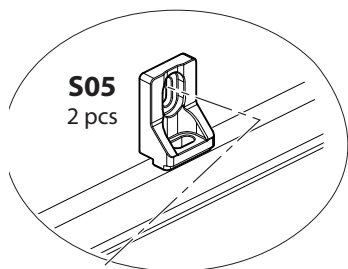

Serrare le viti  
Tighten the screws

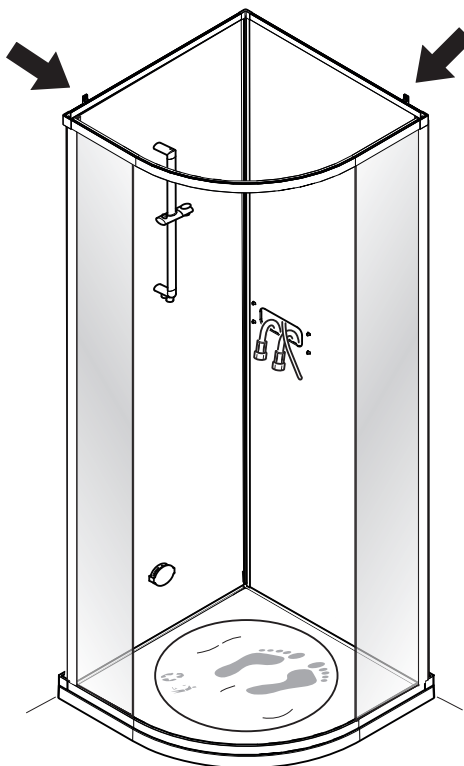
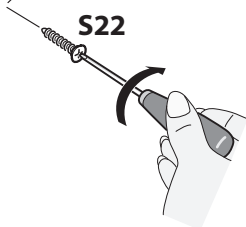
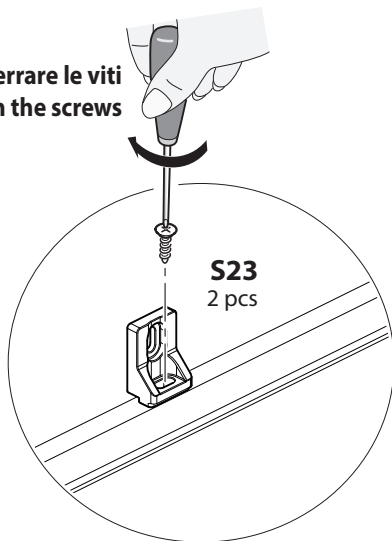

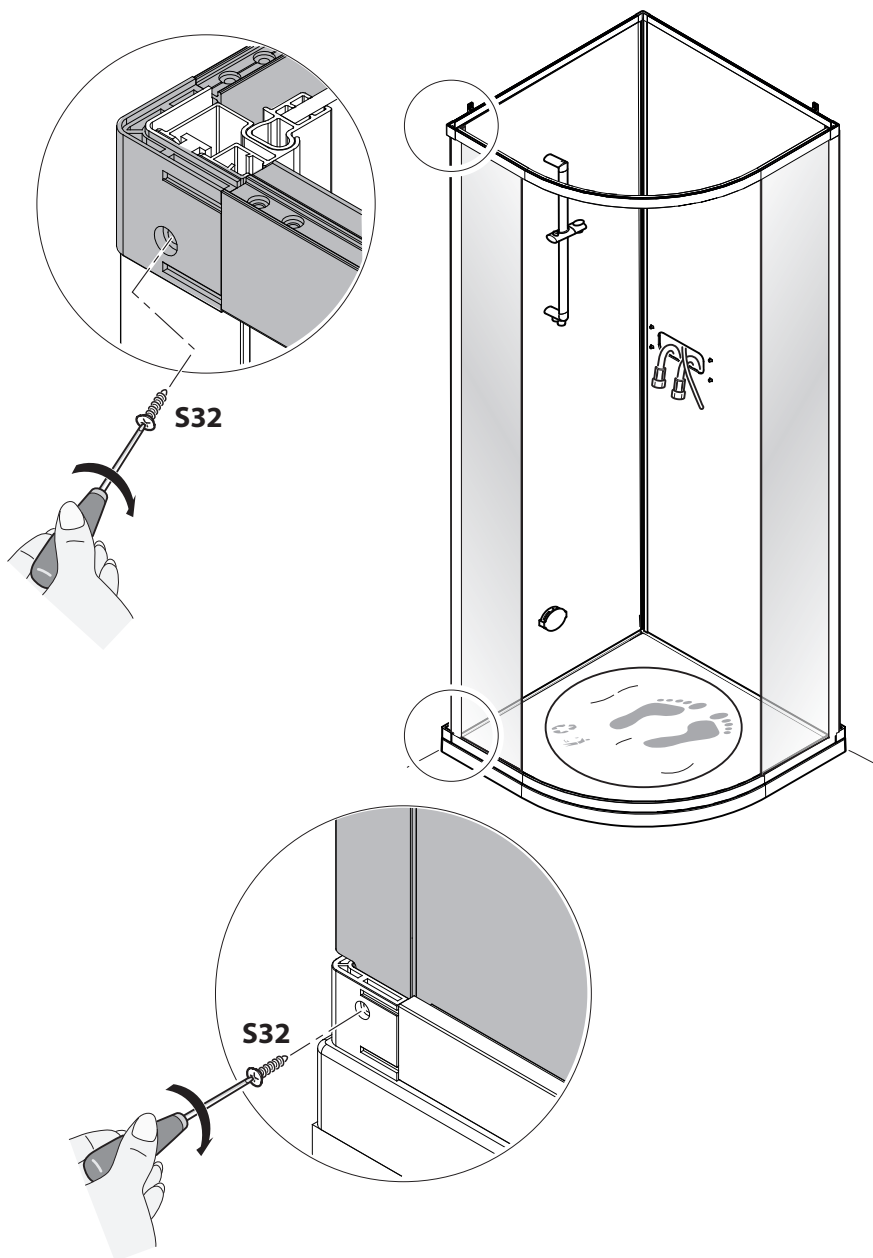

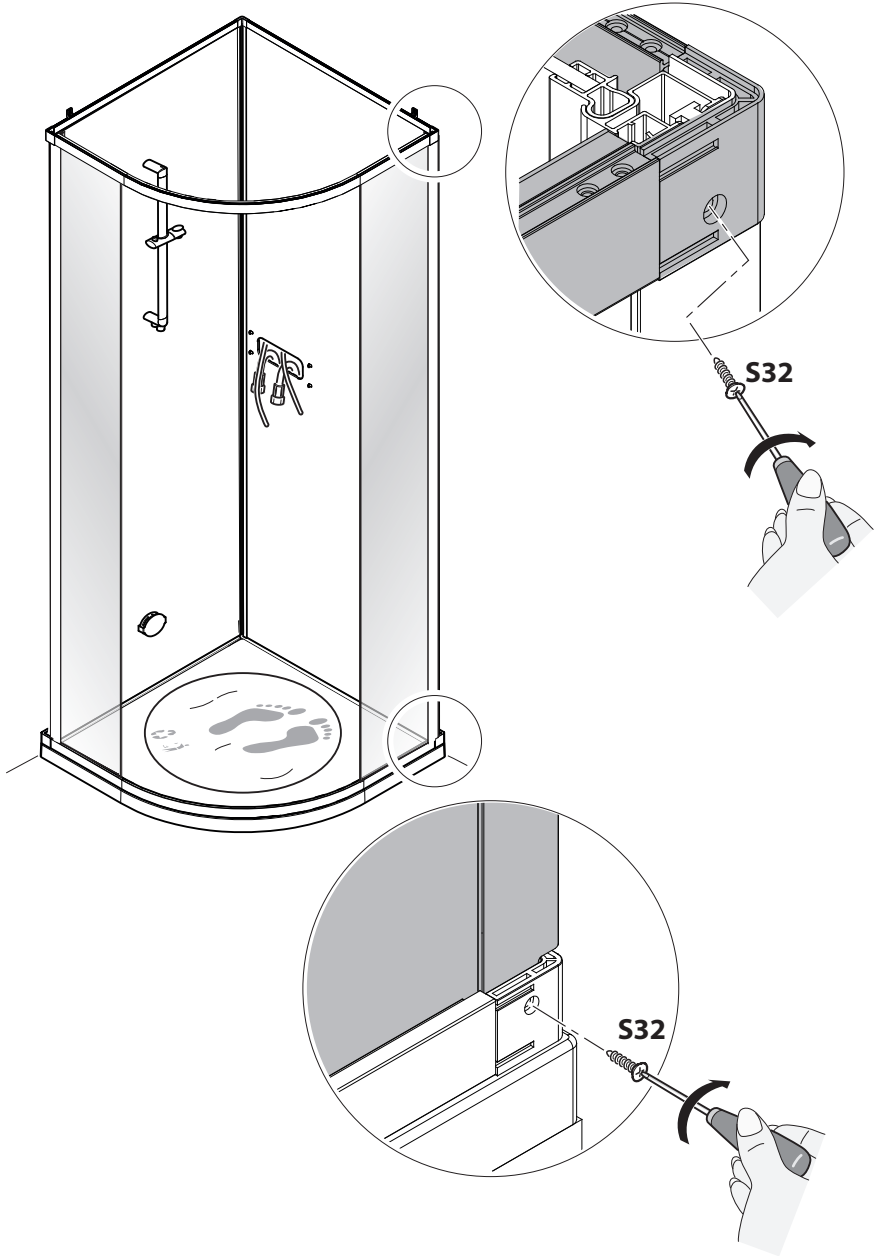

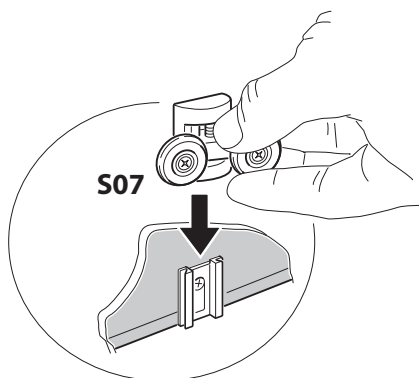
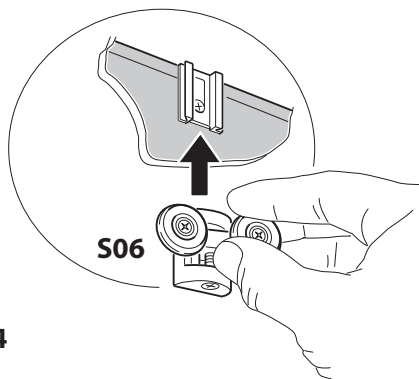
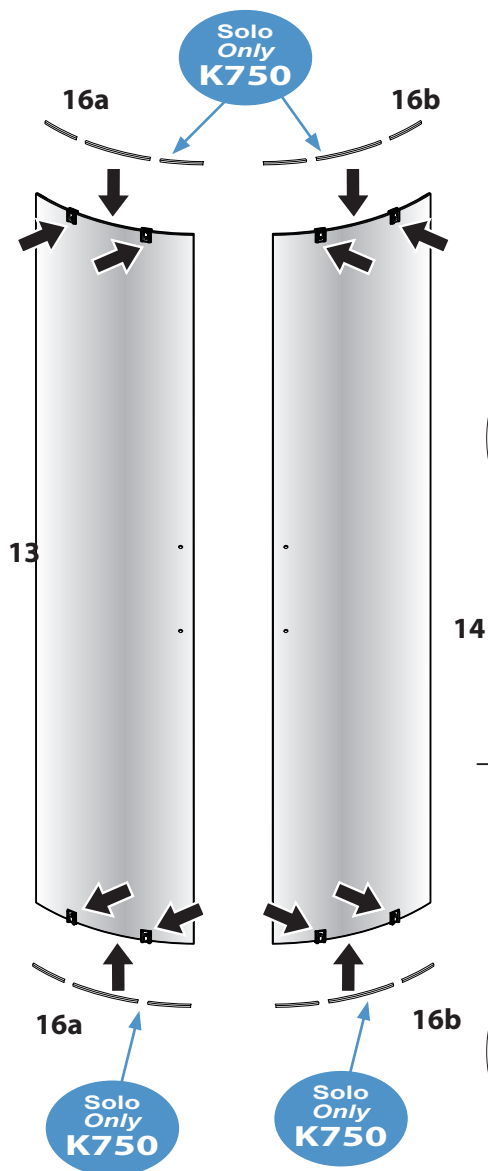

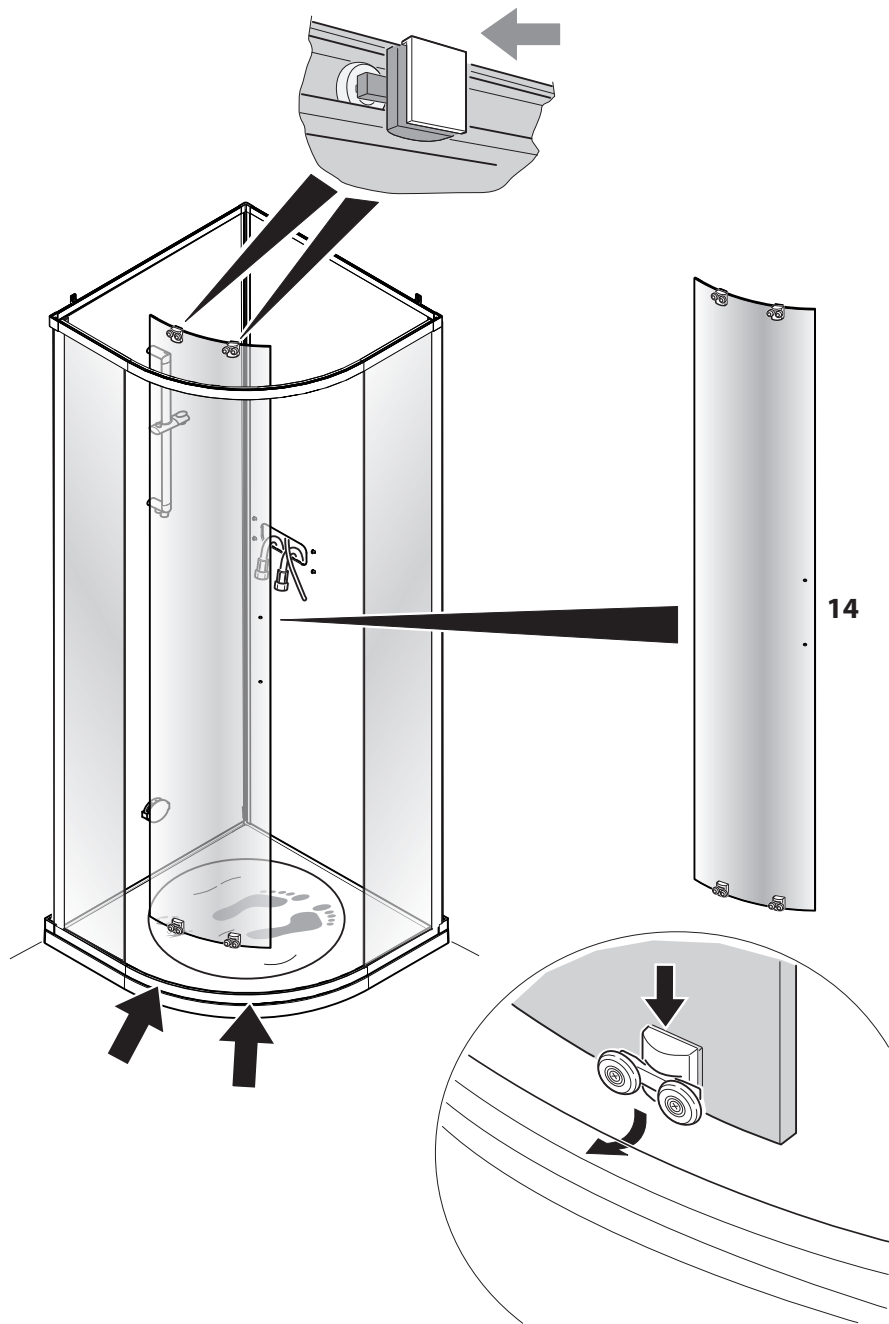

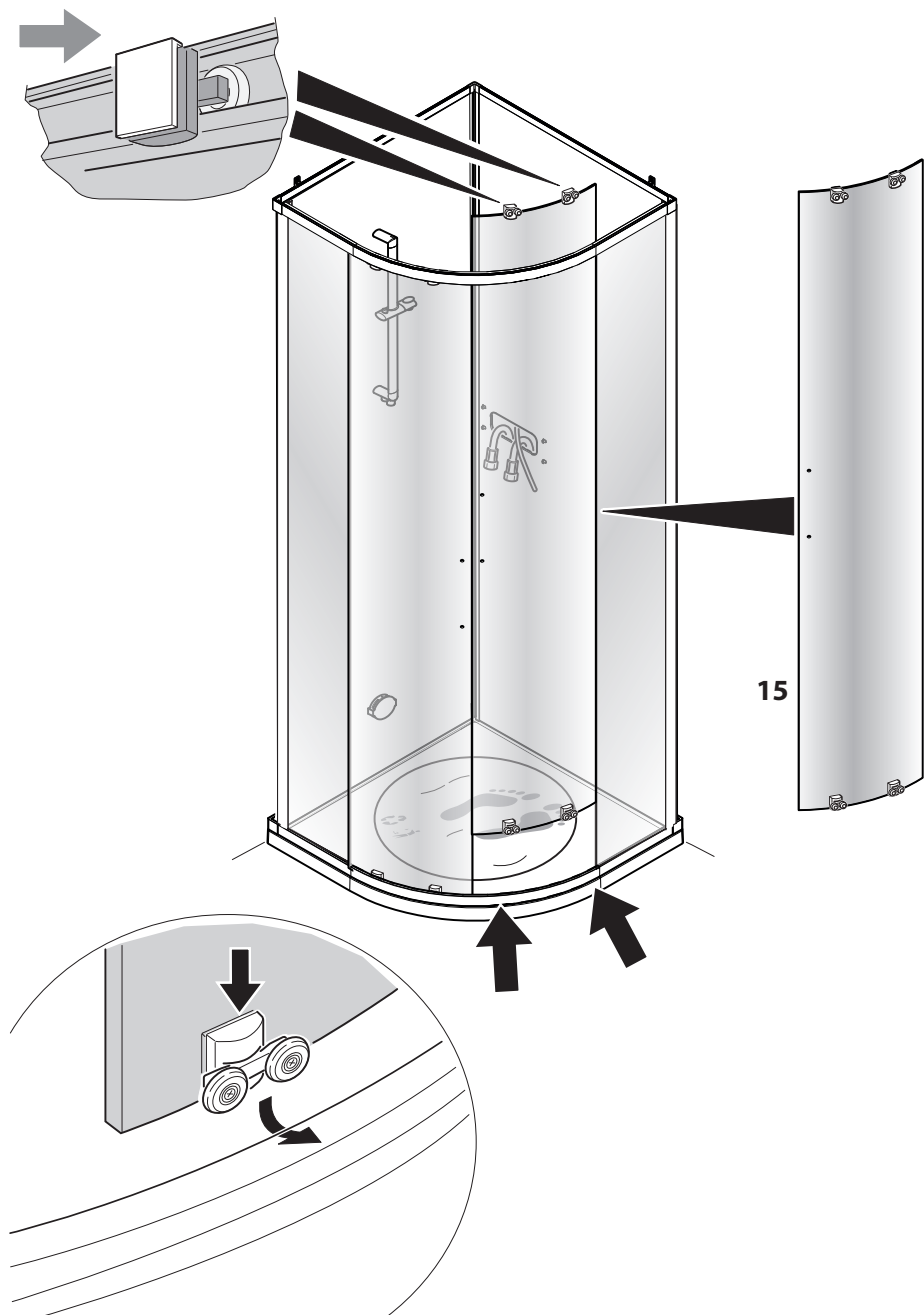

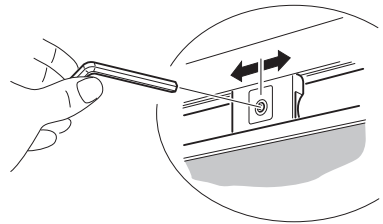
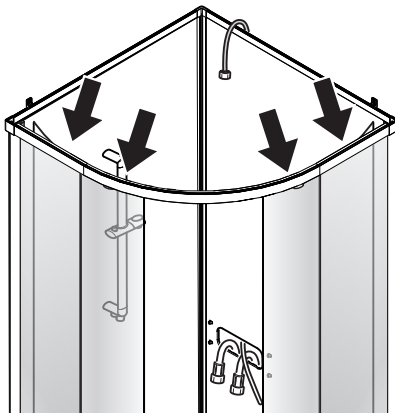
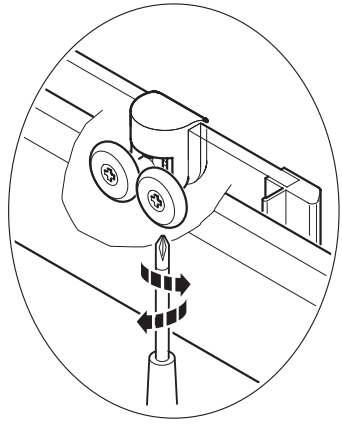
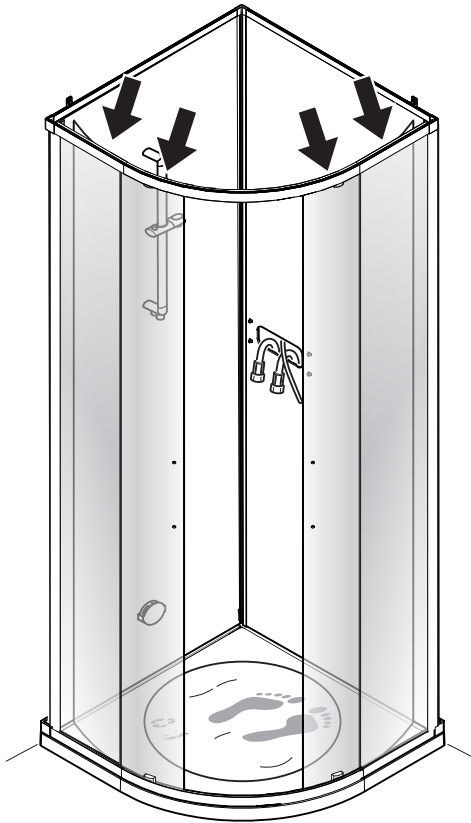

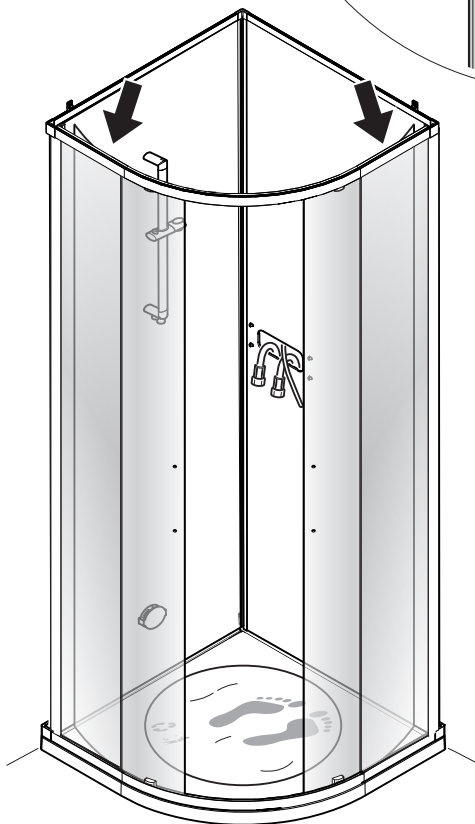
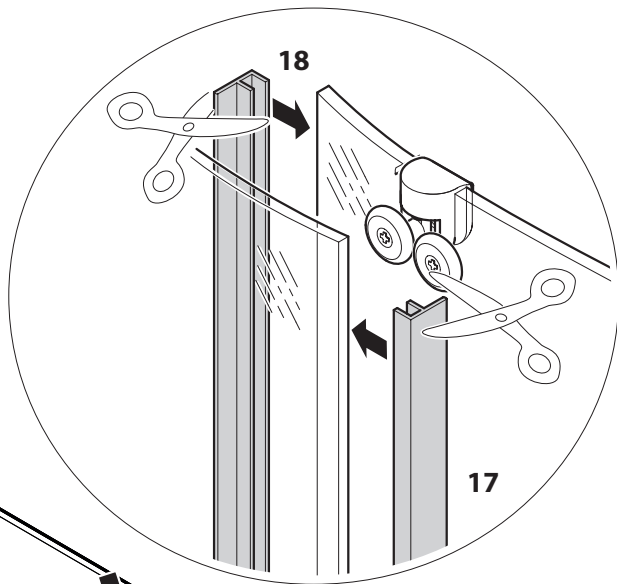

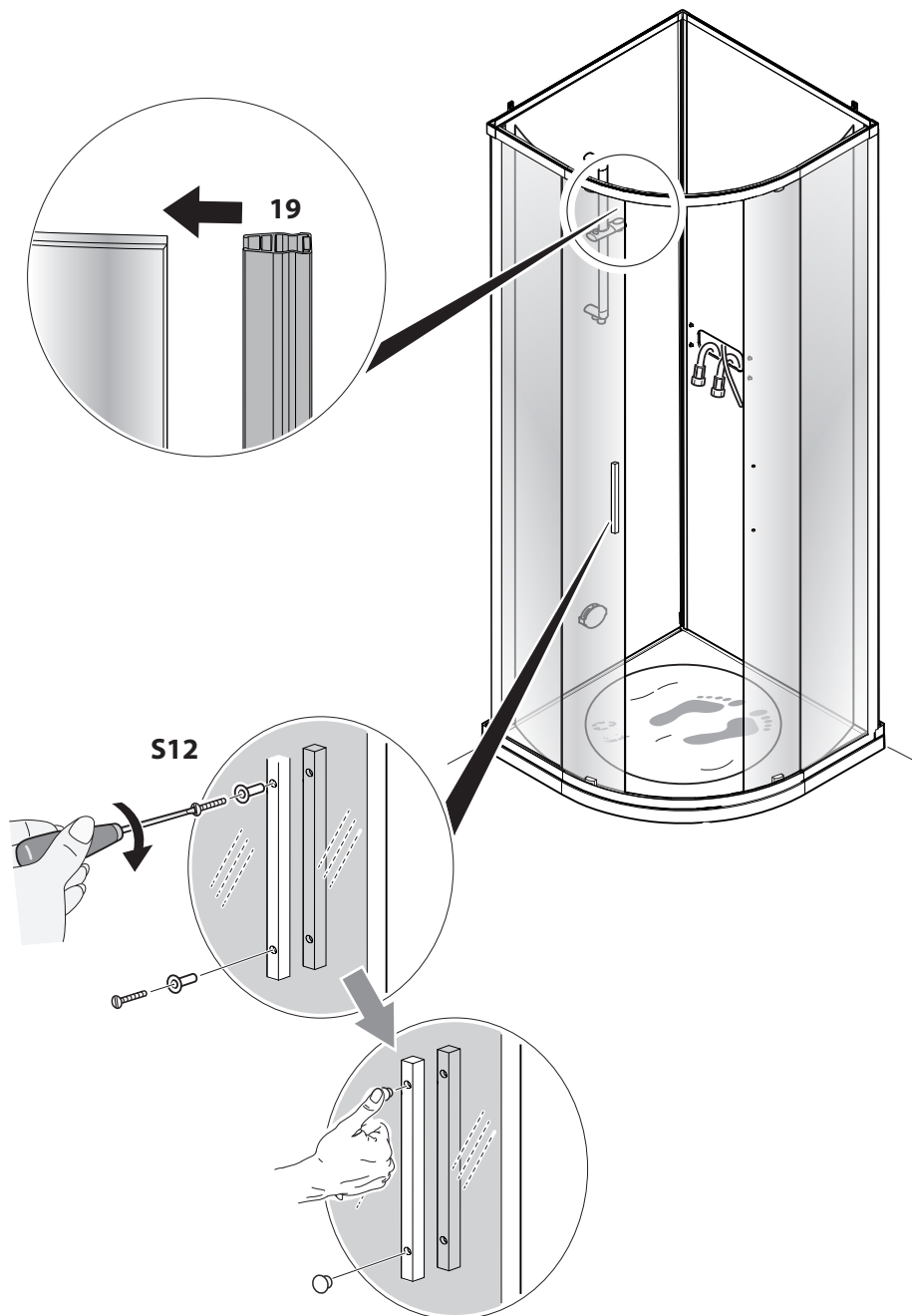

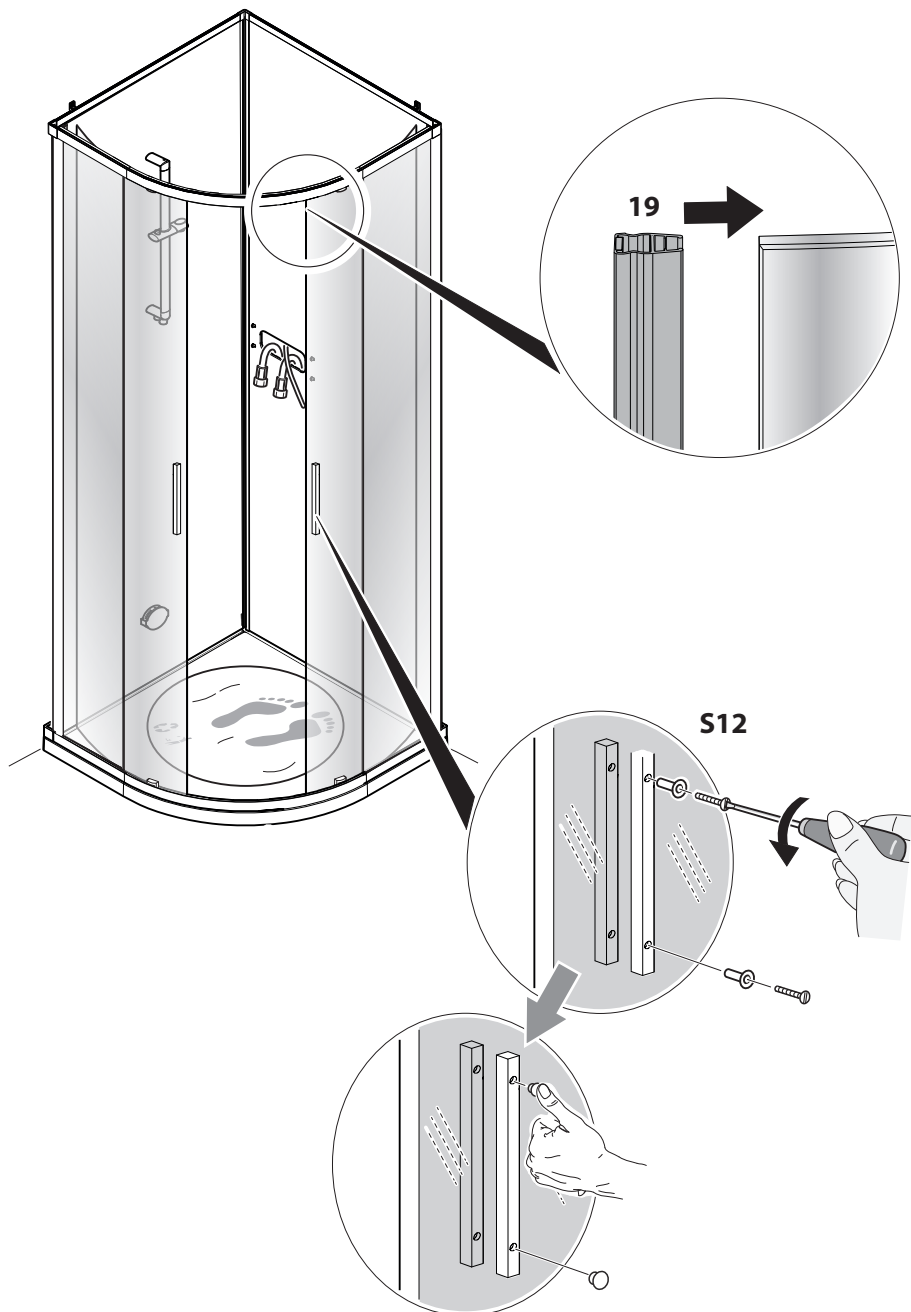

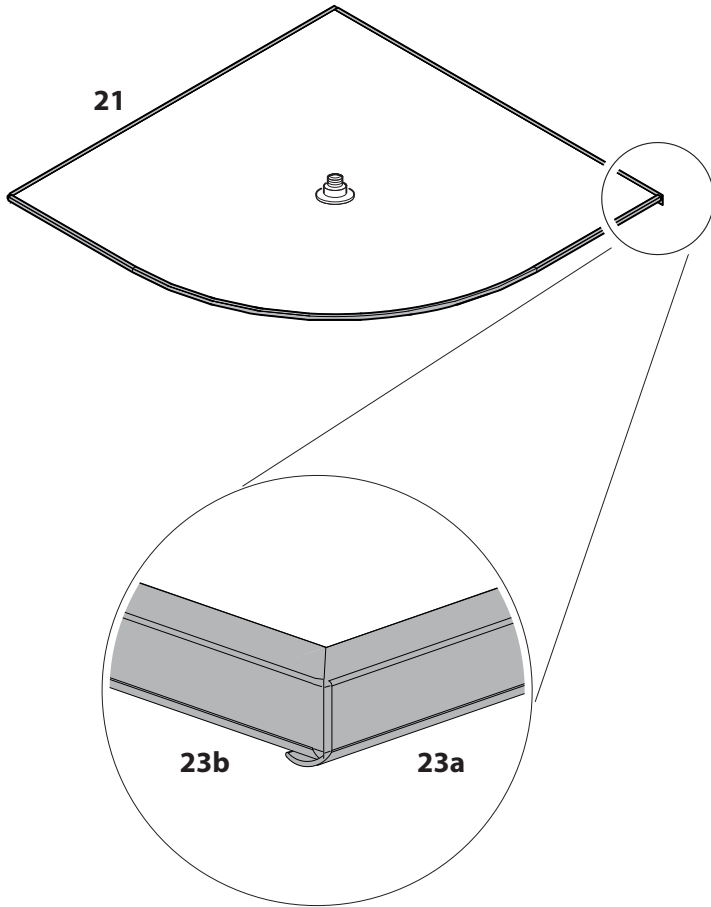

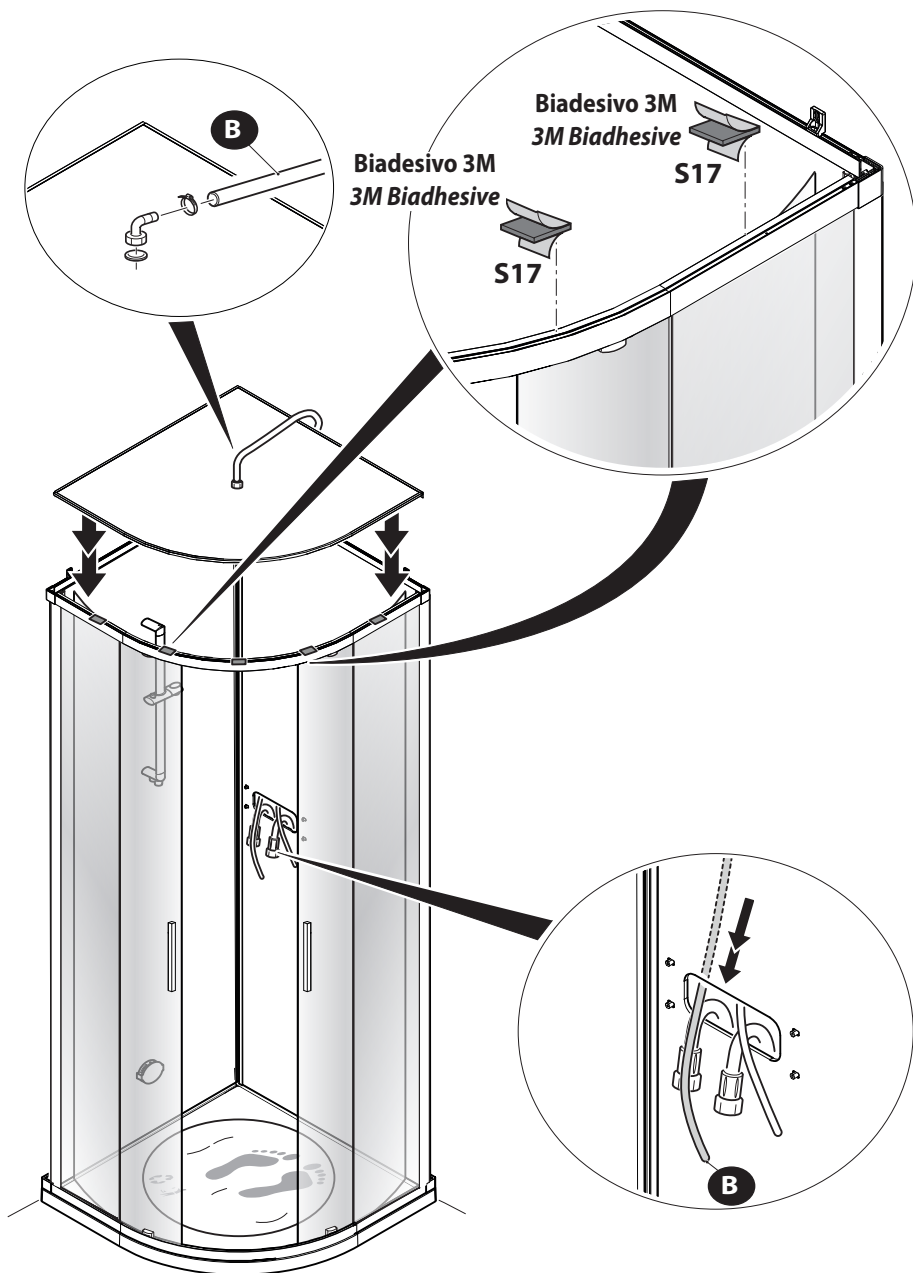

**Far passare i tubi tra cornice e tetto  
dalla parte del bordo tetto ribassato**

**Make the pipes pass between the  
frame and roof from the lowered roof  
edge side**

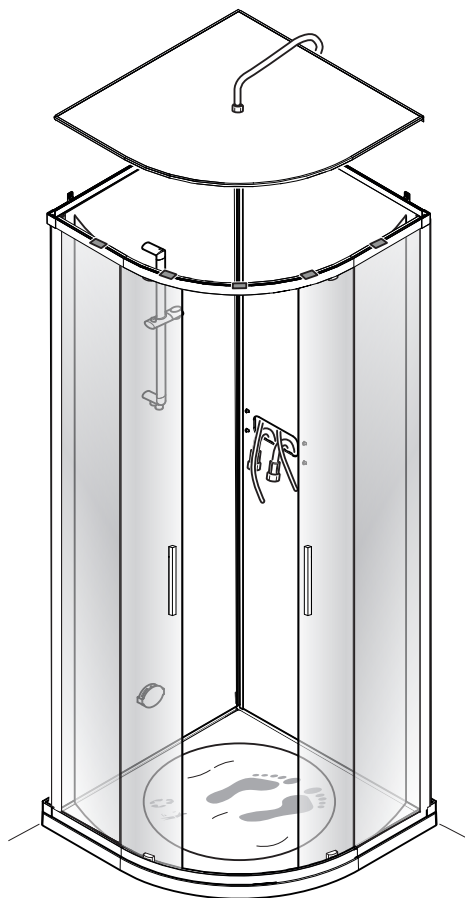

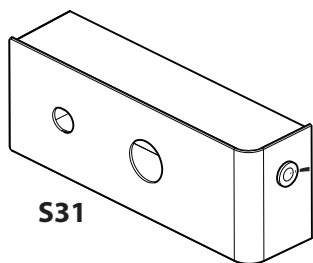
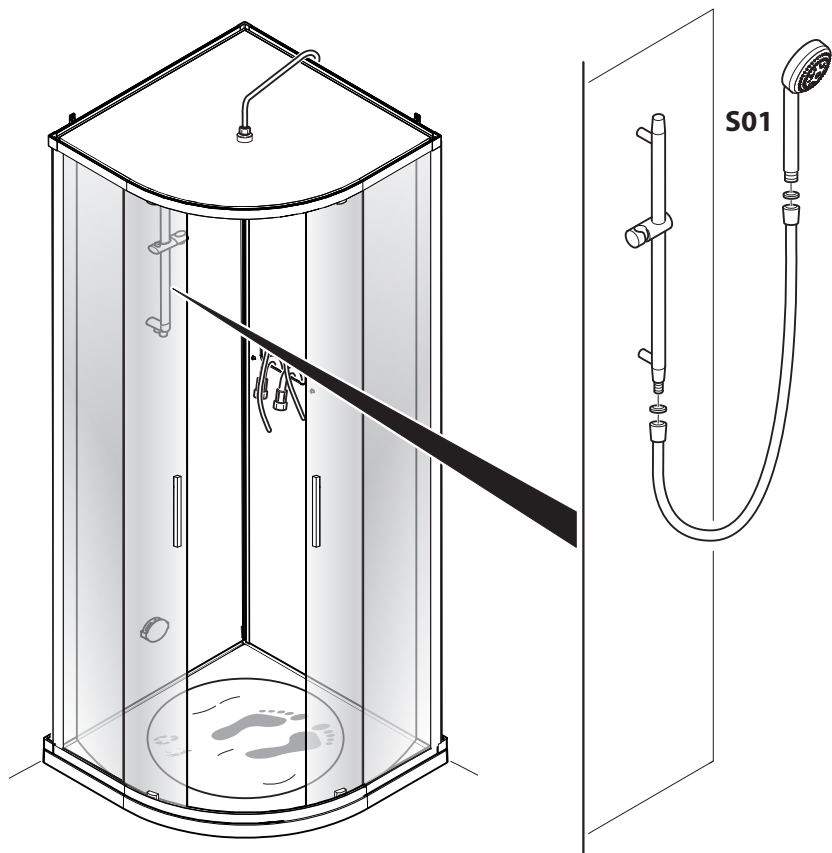

**Solo  
Only  
K750**

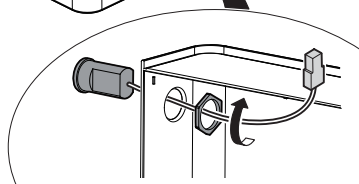

K500

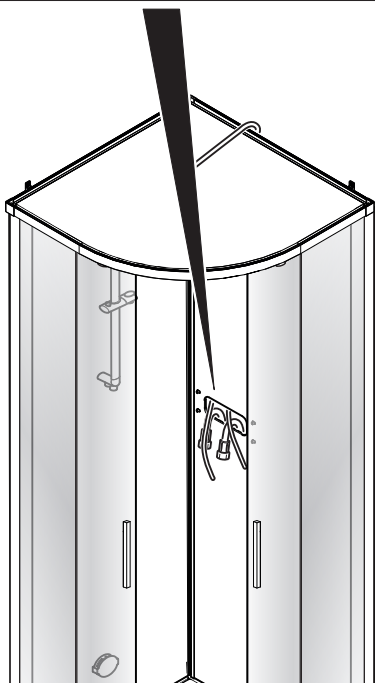
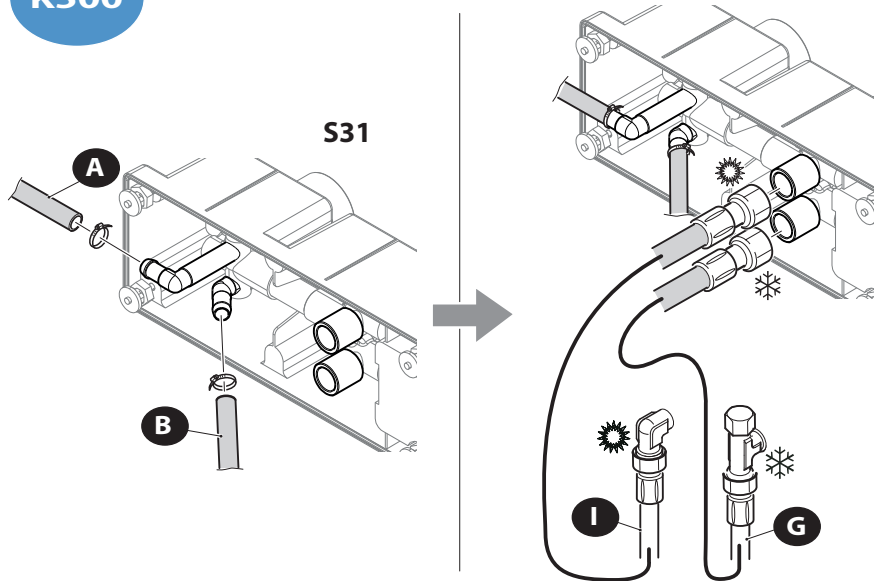

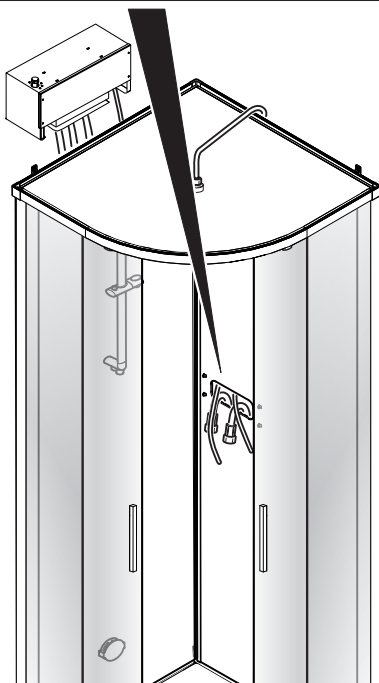
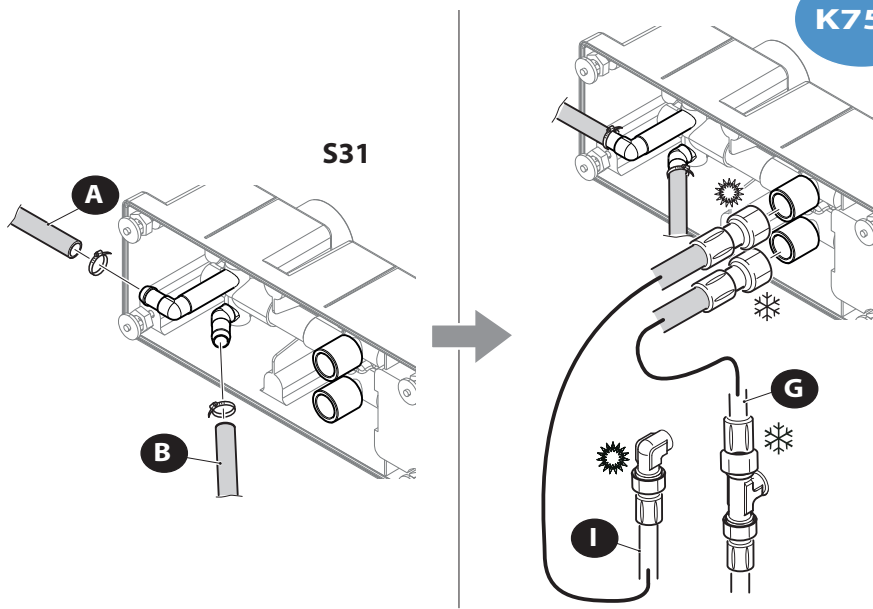

K500

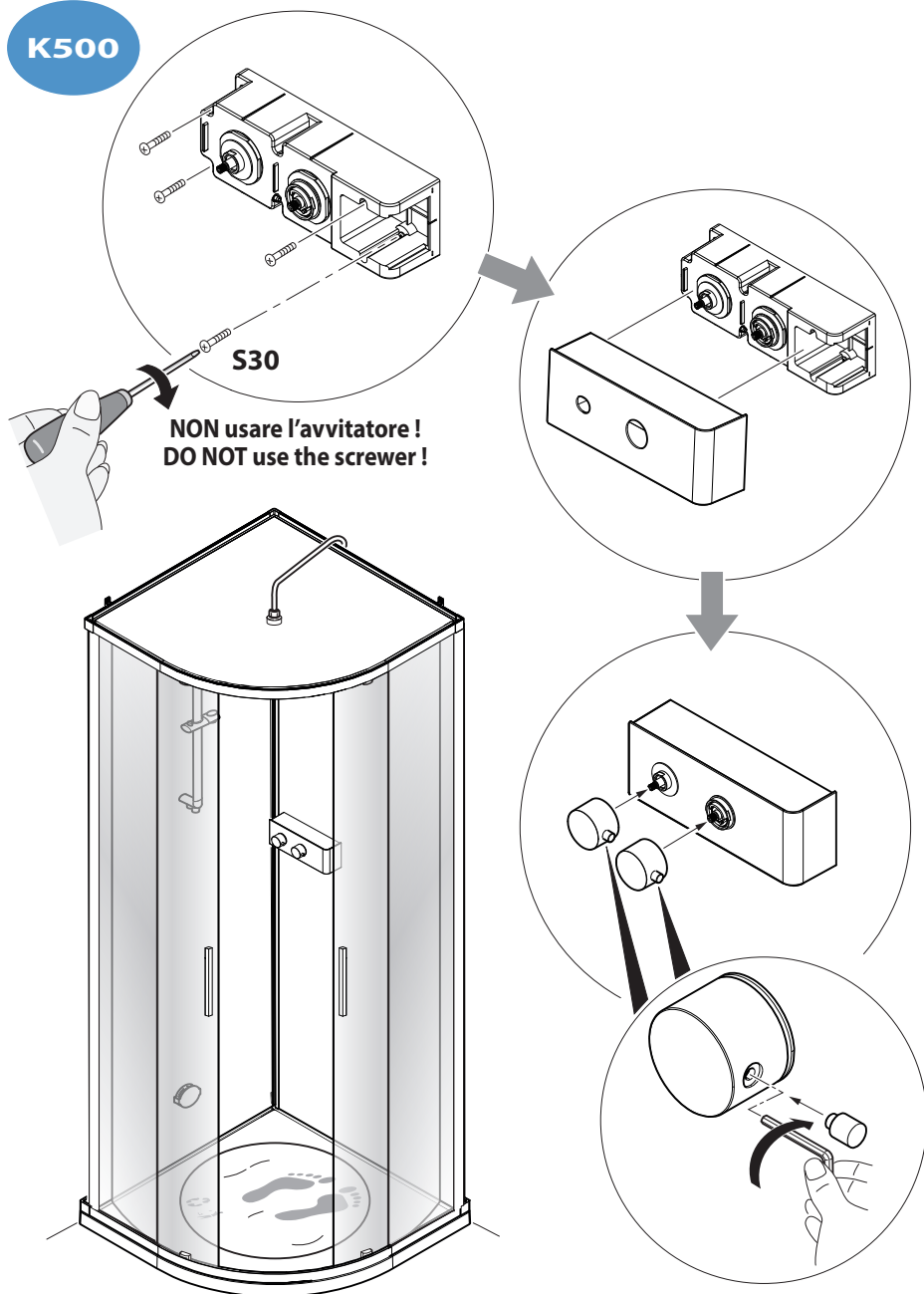

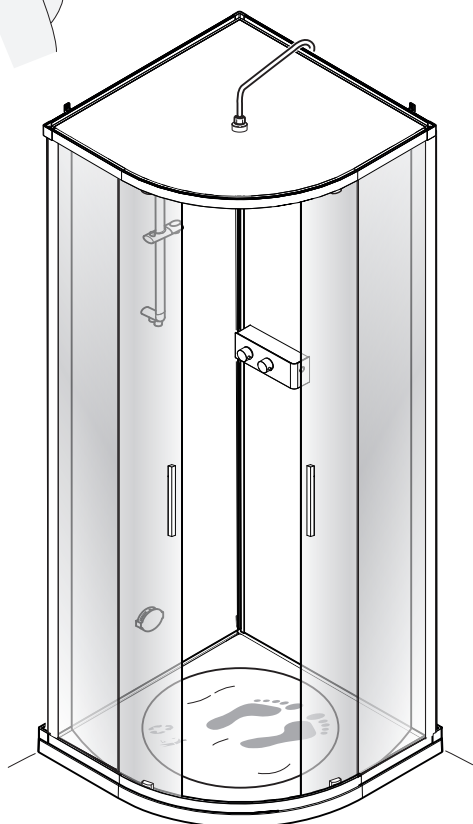
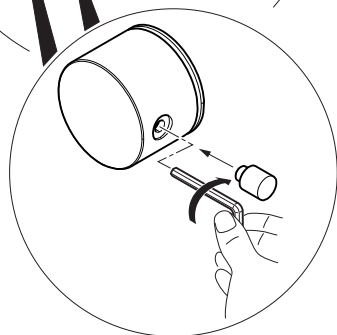
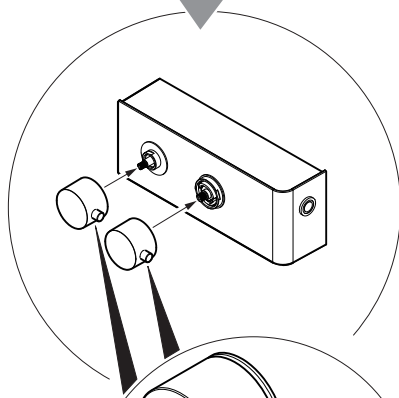
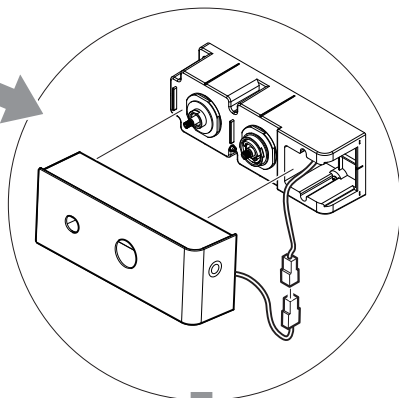
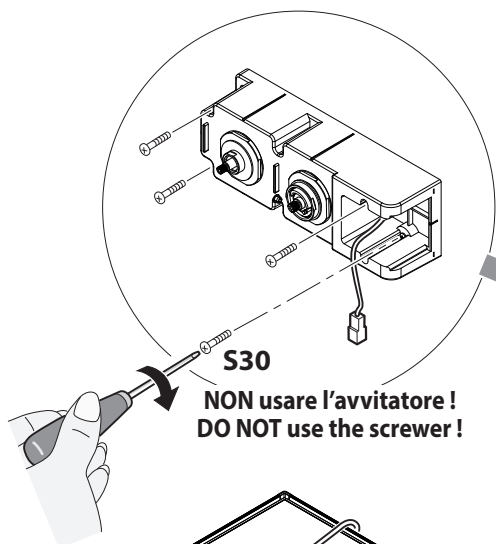

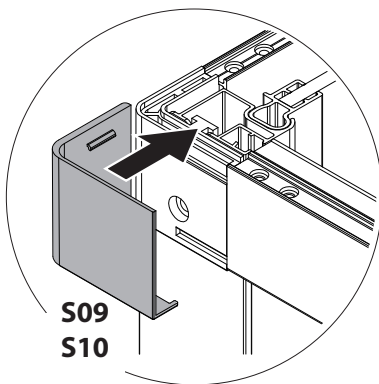
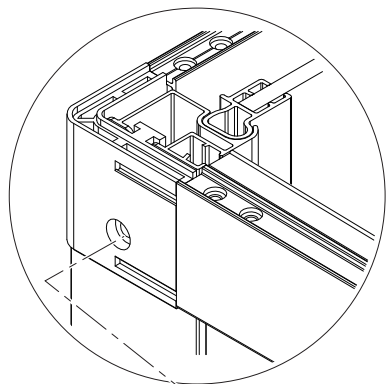

S09  
S10



S23

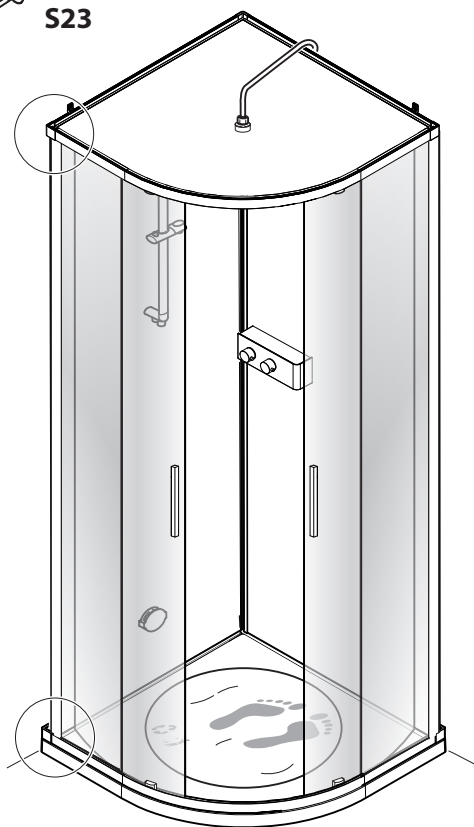

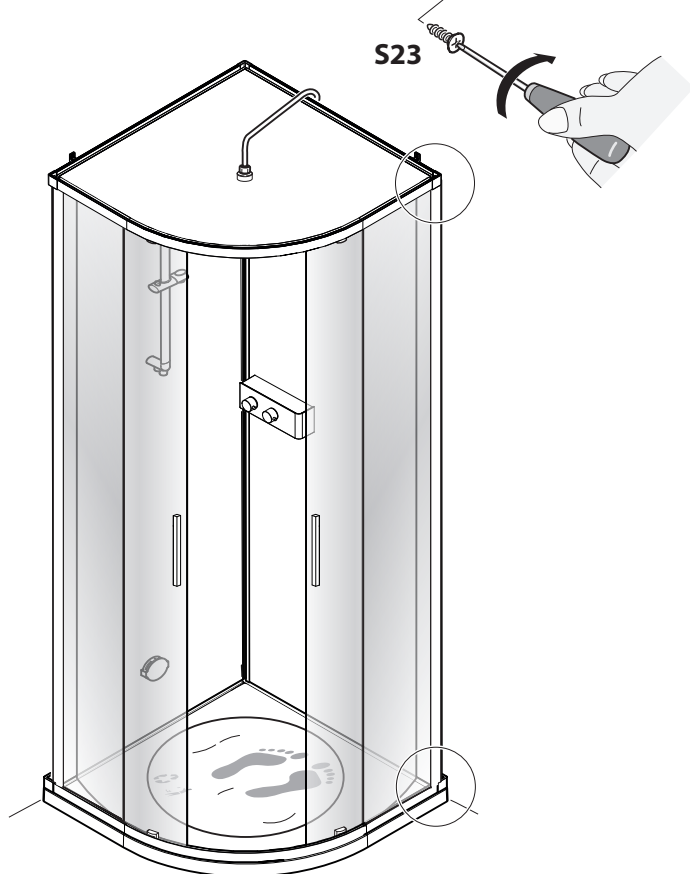
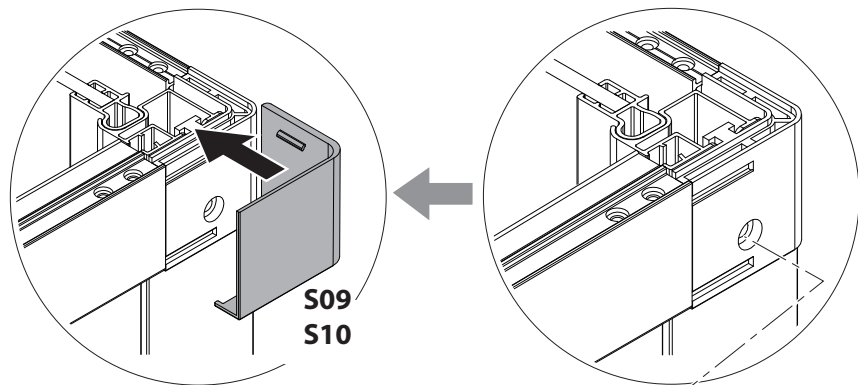

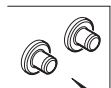
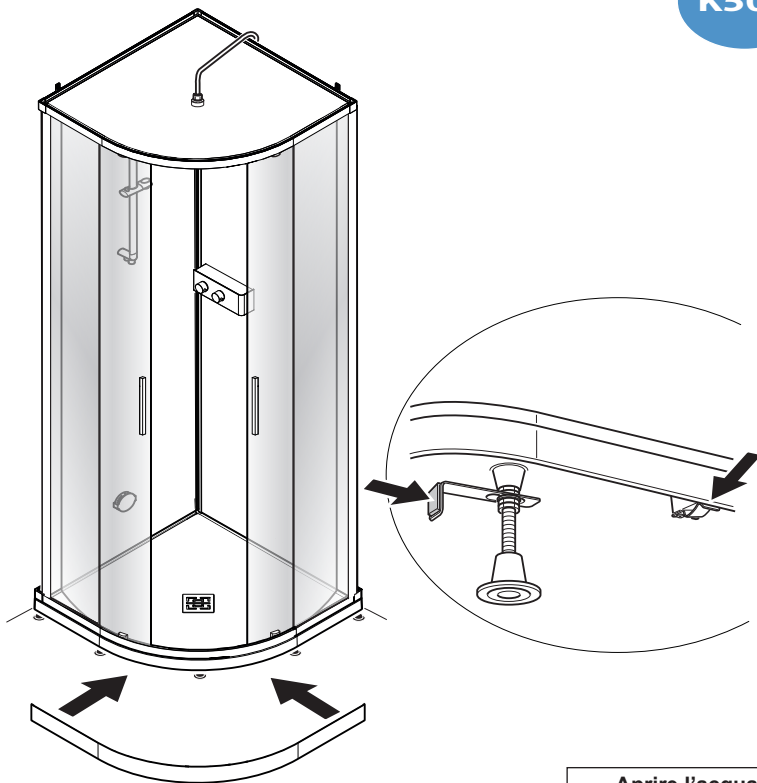

Aprire l'acqua

Open water

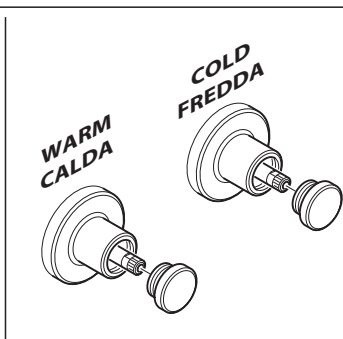
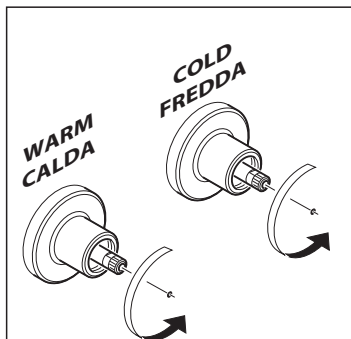

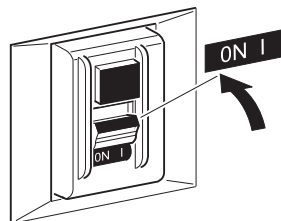
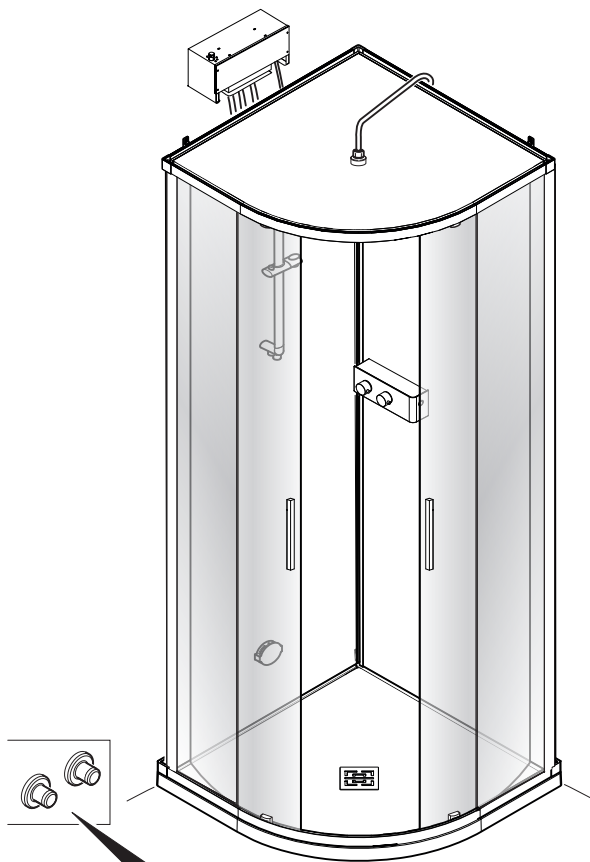

**Dare tensione  
alla cabina doccia**

**Power up the  
shower cabin**

**Aprire l'acqua**

**Open water**

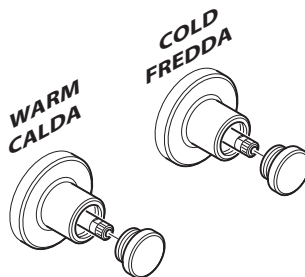
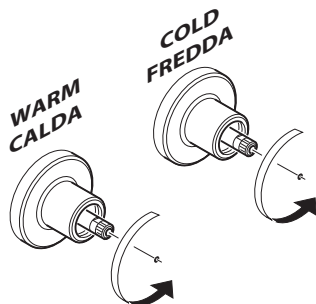

- **Non aggrapparsi al tetto.**
- ***Do not hang to the shower profile.***

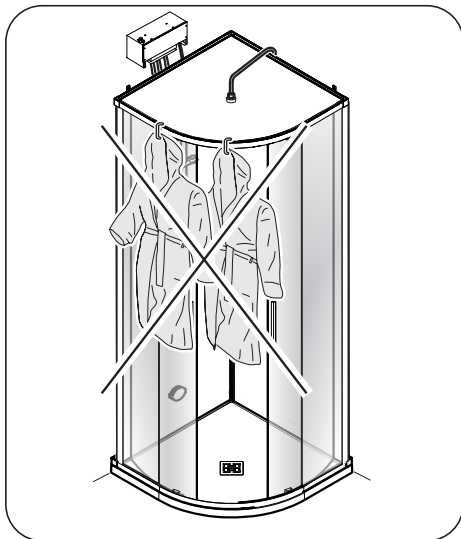
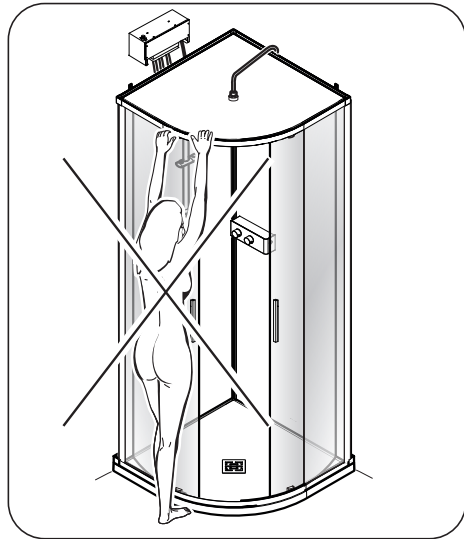

- **Non appendere oggetti pesanti al tetto.**
- ***Do not hang heavy objects to the shower profile.***